

Development of Transducer for Photoacoustic Imaging Employing Sol-Gel Composite Spraying Technique

ゾルゲル複合体スプレー法を用いた光音響イメージング用振動子の開発

Masayuki Tanabe^{1†‡}, Tai-Chien Wu², Makiko Kobayashi¹, Masahiko Nishimoto¹, and Che-Hua Yang²

(¹Fac. Adv. Sci. Technol., Kumamoto Univ.; ²Inst. Mfg. Tech., Taipei Tech. Univ.)

田邊将之^{1†‡}, 吳岱杰², 小林牧子¹, 西本昌彦¹, 楊哲化²

(¹熊本大院 先端科学研究部, ²台北科技大 機電学院)

1. Introduction

Photoacoustic (PA) imaging is a novel imaging technique which provides optical absorption and acoustic penetration, and it has experienced with many applications in biomedicine field⁽¹⁻⁴⁾. Although various shapes of transducers have been developed to obtain ultrasonic wave efficiently in optical-resolution photoacoustic microscope (OR-PAM), there remains room for improvement. When using a single element transducer in OR-PAM, the beam axis should be the same as the optical beam axis and the receiving surface should fit with the wave front the emitted point-shape wave. Recently, we have developed piezoelectric transducers employing sol-gel composite spraying technique in several fields^(5,6). In this paper, we present an improved transducer for PA imaging by employing automatic spraying machine.

2. Method

2.1 Fabrication of transducer

In this study, the PZT/PZT layer was fabricated by sol-gel composite spray method. The mixture of PZT powder and PZT sol-gel solution was sprayed on a stainless-steel rod by an automatic spraying machine. The rod is 13 mm diameter and 5 mm height stainless steel rod with a hole of 3 mm diameter and curved surface which curvature rate is 5 mm diameter and 2 mm depth. After each spraying the PZT/PZT composite, drying at 150°C and firing at 650 °C for 5 min each were performed. These spraying, drying and firing processes were repeated to the desired thickness. After PZT/PZT fabrication process, corona poling was performed at room temperature. Subsequently, colloidal silver was sprayed on the curvature area by an air brush and wires were bonded. Consequently, the transducer was coated with parylene for waterproof. Fabricated transducer is shown in Fig. 1. The piezoelectric d constant, d_{33} is approximately 70 pC/N.

2.2 Experimental conditions

A pulse-echo experiment was conducted to evaluate the fundamental performance of the fabricated transducer. The PA experiment was also conducted, as shown in Fig. 2. Pulsed laser with a wavelength of 532 nm and an energy of 0.6 μJ, was used to generate the PA signal. Human hairs embedded in a phantom with a sound velocity approximately 1500 m/s were used as the target. The receiver preamp gain was set to 60 dB.

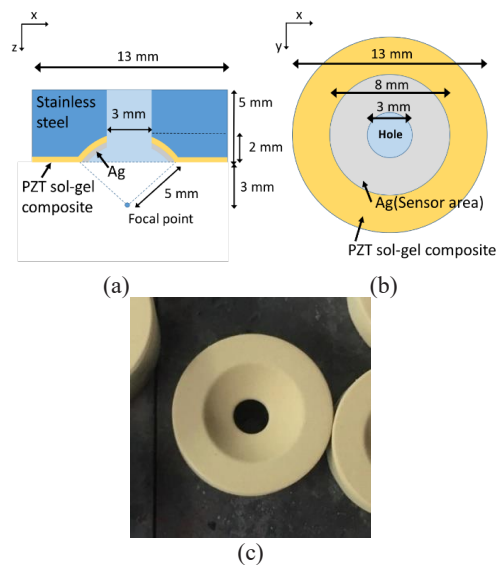

Fig. 1 Fabricated transducer. (a)(b) Designs of transducer. (c) Photos after connecting wires.

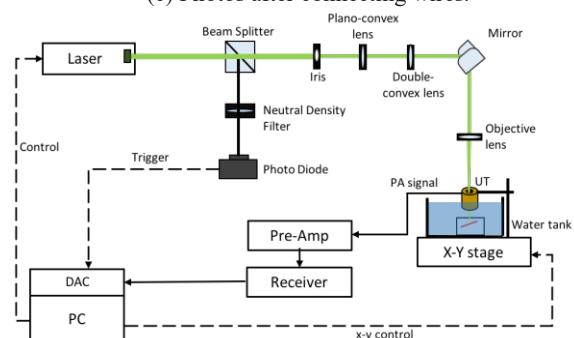

Fig. 2 Experimental setup.

3. Results

The obtained echo signal from stainless block in pulse-echo experiment is shown in Fig. 4. Two-dimensional maximum amplitude projection (MAP) images of hairs using at various depths were also obtained, as shown in Fig. 5. An example of PA signal is shown in Fig. 6.

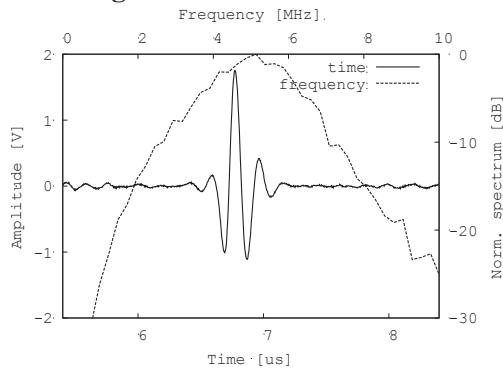

Fig. 4 Echo signal from stainless block in pulse-echo experiment in time (solid line) and frequency (dash line) domains.

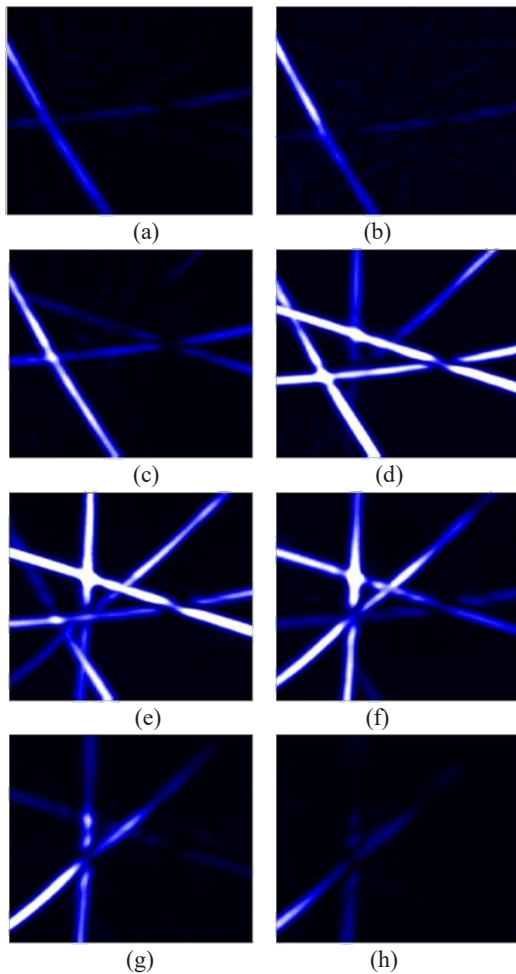

Fig. 5 MAP images of hairs at depth of (a)0.5, (b)1.0, (c)1.5, (d)2.0, (e)2.5, (f)3.0, (g)3.5 and (h)4.0 mm.

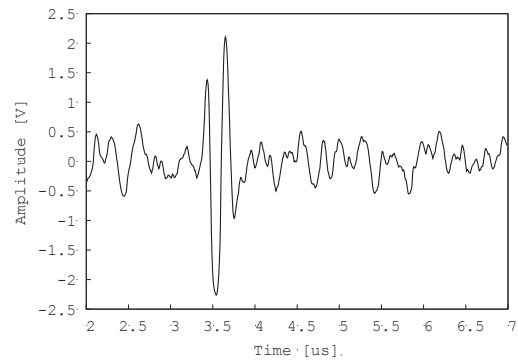

Fig. 6 PA signals from hair.

4. Conclusion

In this study, a concave transducer employing sol-gel composite spray technique was fabricated using the automatic spraying machine, and a fundamental pulse-echo and PA experiments were conducted.

References

1. J. Yao and L. V. Wang: *Laser Photon Rev.* **7** (2013) doi:10.1002/lpor.201200060.
2. H. Estrada, J. Turner, M. Kneipp and D. Razansky: *Laser Phys. Lett.* **11** (2014) 045601.
3. J. Yao and L. V. Wang: *Photoacoustics* **2** (2014) 87.
4. E. M. Strohm, M. J. Moore, and M. C. Kolios: *IEEE UFFC* **22** (2016) 6801215.
5. M. Tanabe, K. Hirata, M. Kobayashi, M. Nishimoto, Tai-Chien Wu and Che-Hua Yang: *Proc. IEEE Int. Ultrason. Symp.* (2016) doi: 10.1109/ULTSYM.2016.7728734
6. K. Kimoto, M. Matsumoto, T. Kaneko, M. Kobayashi: *Jpn. J. Appl. Phys.* **55**(7S1) (2016) 07KB04.