

Optical Interferometric Measurement of Vibration Amplitude in High Power Ultrasonic Tool through Vibration-Synchronized Fringe Counting

光学干渉縞の同期計数によるパワー超音波振動系の振動振幅測定

Kentaro Nakamura[†] (Tokyo Inst. of Tech.)

中村健太郎[†] (東工大)

1. Introduction

Vibration frequencies of 20-100 kHz are mostly used for high power ultrasonic applications such as cleaning, welding, machining, and chemical reactions [1]. In most of these applications, vibration displacement amplitude ranges from several to several ten μm . Laser Doppler velocimeter (LDV) is widely used to measure the vibration amplitude in laboratories. However, it is not necessarily accepted by developer or vender companies of ultrasonic tools. This is probably because of the cost of LDV system.

In this report, the author investigates a cost-efficient optical interferometer to measure the vibration displacement amplitude of high power ultrasonic vibration systems working at several 10 kHz with the vibration amplitude of beyond μm -range. The key of the proposed system is the counting of the interferometric fringes synchronized with the driving signal of the vibration system. This becomes possible when the vibration is continuous sinusoidal one, and can eliminate the acousto-optic modulator (AOM) in the heterodyne LDV [2], which is thought a costly component. Replacement of the He-Ne laser by laser diode (LD) will be also tried. To use LD in interferometer is not necessarily low cost in general, because a precise control of the current and temperature is inevitable for LD. The reduction in these electrical circuits will be studied for the proposed system.

2. Interferometer Configurations

Practical LDV is composed of a heterodyne interferometer as shown in Fig. 1. A frequency shift of 40-200 MHz is applied on the reference light with an AOM in a modified Mach-Zehnder interferometer. The photo detector (PD) output is a frequency modulated (or phase modulated) signal centered at the shift frequency. Circular polarization is used for the light illuminating the vibrating object in many of commercial LDVs. Fig. 2 illustrates the Michelson homodyne interferometer and the synchronous fringe counting circuit considered in this study, where the AOM is eliminated. The ratio of the intensity of the illuminating light to the

reference light can be optimized in this setup by rotating the direction of polarization of the light source. In the simplified configuration shown in Fig. 3, the intensities of the illuminating and reference lights are fixed.

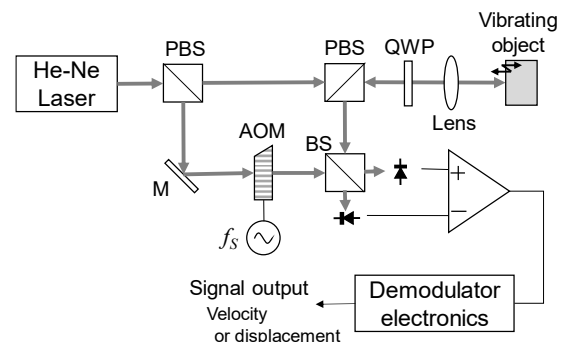

Fig. 1 Diagram of heterodyne LDV: AOM, acousto-optic modulator; BS, beam splitter; M, mirror; PBS, polarization beam splitter; QWP, quarter wave plate.

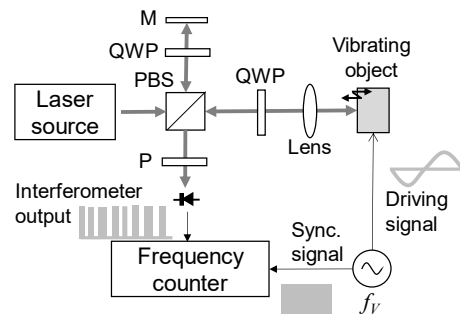

Fig. 2 Homodyne interferometer and synchronized fringe counting circuit for vibration displacement measurement: P, polarizer.

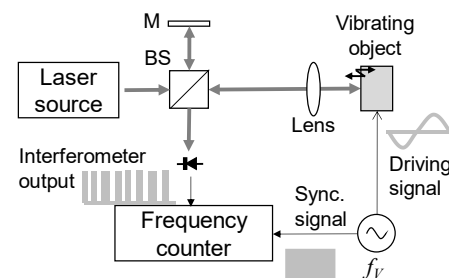

Fig. 3 Simplified homodyne interferometer: BS, non-polarized beam splitter.

3. Theory of Interferometric Signals and Fringe Counting

The AC component of the electrical output of the PD is expressed with the 0-p displacement u and the frequency f_V of the ultrasonic vibration as

$$i_{AC} \propto \cos 2\pi \left(\frac{2u}{\lambda} \cos 2\pi f_V + \frac{\Delta x}{\lambda} \right). \quad (1)$$

Here, λ and Δx are the light wavelength and the initial phase difference between the two light paths, respectively. Assuming a He-Ne laser as the light source, $\lambda=0.6328 \mu\text{m}$, examples of interferometric waveforms are calculated using Eq. (1) as shown in Fig. 4 for the peak-to-peak vibration amplitude ($=2u$) of $2 \mu\text{m}$. Though the waveform changes with the path difference Δx , number of counting of the interferometric waves in one cycle of the vibration varies by one depending on the path difference (initial phase), and this error corresponds to $0.16 \mu\text{m}$. The proposed method indicates 2.06 or $1.90 \mu\text{m}$ for this given vibration amplitude of $2.00 \mu\text{m}$.

4. Experimental Evaluation

In the practical experiments, a 3-mW linear polarized He-Ne laser was utilized, and the measurement light was focused on the sample vibrator through an objective lens with the magnification of 5. We prepared a 37.5-kHz stepped horn driven with a Langevin transducer. The surface of the aluminum horn was diffused surface finished with #800-1000 sand paper. A Si-pin photo diode was used with a pin hole and a post amplifier having the gain of 40-50 dB. The electronic circuit needs to have frequency response up to several MHz since the number of fringes in one cycle of the vibration changes from several to several ten.

A simple digital counter was employed to count the fringes, where the counter was gated with the driving signal for the vibrator.

Two examples of experimentally observed fringe patterns are pasted on Fig. 5 when the vibration displacement amplitude is around $2 \mu\text{m}$. Similar results as the theory shown in Fig. 4 were successfully obtained. To count the number of fringes with less error, saturated waveforms as shown in Fig. 5(b) is better. Actual voltage amplitude of the fringes appeared at the output of the post amplifier was from 10 mV to 1 V, which was enough as the input to the counter circuit. Almost equal results were obtained as a commercial LDV as plotted in Fig. 6.

3. Conclusions

A simple fringe counting of homodyne interferometer was investigated for absolute measurement of power ultrasonic tools of 20-100

kHz. Precise results were obtained with less expensive system. Reduction in the cost of light source will be considered.

References

1. K. F. Graff and J. A. Gallego-Juárez, 'Power Ultrasonics,' Woodhead Publishing, NY, 2014.
2. M. Johansmann and G. wirth, Chap. 9, 'Ultrasonic transducers,' Woodhead Publishing, NY, 2012.

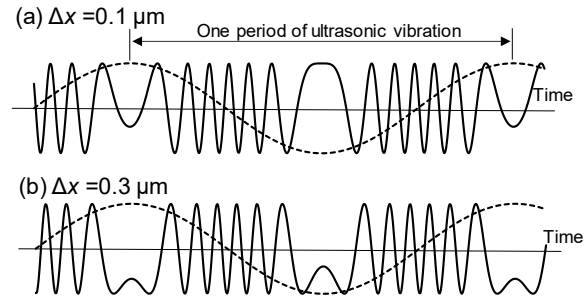

Fig. 4 Examples of theoretical interferometric waveforms for the vibration amplitude of $2 \mu\text{m}$.

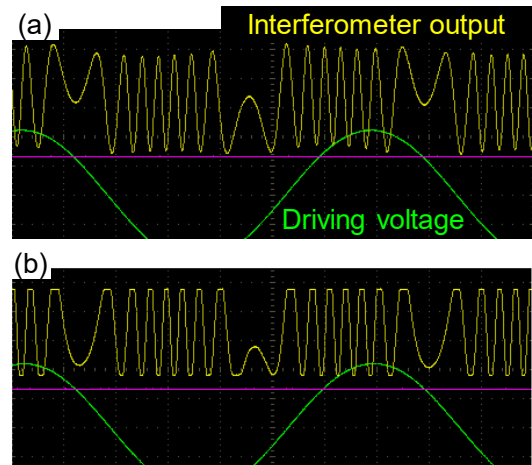

Fig. 5 Examples of measured fringe patterns with driving voltage waveform of transducer: (a), low gain; (b), high gain post amplifier for vibration amplitude of $2 \mu\text{m}$.

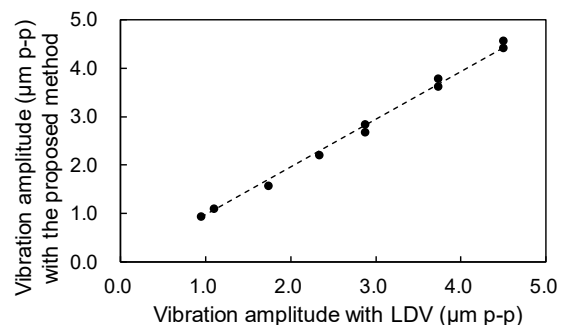

Fig. 6 Vibration amplitudes measured through the proposed method and the LDV.