

Viscoelasticity measurement for living tissue using airborne ultrasonic Doppler method

生体組織の粘弾性計測に向けた空中超音波ドプラ法に関する検討

Ryota Sando[‡], Shinnosuke Hirata, and Marie Tabaru (Tokyo tech)

山洞綾太[‡], 平田慎之介, 田原麻梨江 (東工大)

1. Background

Non-contact viscoelasticity measurements have been in demand in various fields, such as management of fruits and vegetables, development of medical materials, and diagnosis of inflammatory skin [1][2]. Conventional non-contact viscoelasticity measurement techniques often use light wave such as Laser Doppler Velocimeter for vibration measurement. Measurements using light wave are highly accurate, however, affected by the surface condition (unevenness or transparent material) of the measurement target. The purpose of this study is to establish a measurement technique that enables non-contact viscoelasticity measurement even in such situation by using MHz airborne ultrasonic for vibration measurement. In this report, we developed non-contact vibration measurement system using airborne ultrasonic transducer. Estimation of viscoelastic properties of an elastic phantom and a chicken sample were examined for confirmation.

2. Experimental method

2.1 Measurement system

We applied a contact measurement technique of viscoelastic properties [3] to non-contact method by using airborne ultrasound. **Fig. 1** shows experimental setup. A vibrator was set on sample surface for vibration excitation. In this study, a piezoelectric actuator (MTKK16S400F170R, Mechano Transformer) was used as a vibrator. The

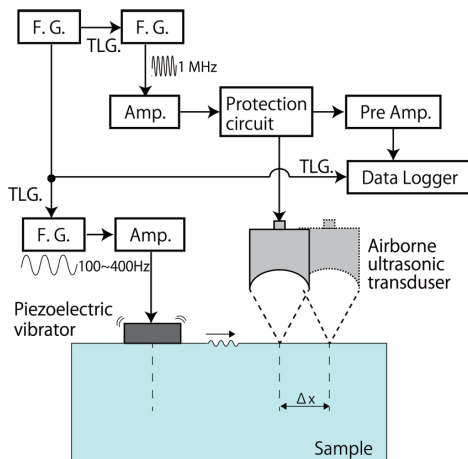

Fig. 1 Experimental setup.

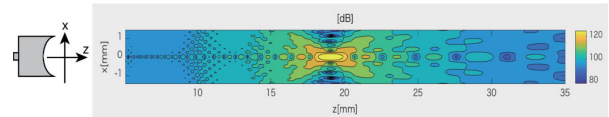

Fig. 2 Pressure distribution of an airborne ultrasonic transducer.

surface wave is detected by an airborne ultrasonic transducer. In this experiment, an airborne ultrasonic transducer (HAR1907225, Japan Probe) with center frequency of 1 MHz, aperture diameter of 24 mm, focal length of 18.5 mm, focal width of 0.7 mm, and focal depth of 5.7 mm was used. **Fig. 2** shows the two-dimensional distribution of energy of the airborne ultrasonic transducer calculated using Huygens' principle [4].

2.2 Estimation principle of viscoelasticity

The phase velocity of a surface wave is expressed by the following equation,

$$c_s(\omega_s) = \omega_s \Delta x / \Delta \phi \quad (1)$$

where Δx is the distance between two points, $\Delta \phi$ is the phase difference, and ω_s is the center frequency of the surface wave [3]. It is known that Rayleigh waves propagate on a solid surface such as a living tissue. The propagation speed of the Rayleigh wave is approximated by the following equation,

$$c_s = \frac{1}{1.06} \sqrt{\frac{\mu}{\rho}} \quad (2)$$

where μ is the shear modulus and ρ is density. When the Voight model is applied to Eq. (2), an equation containing a viscosity coefficient is obtained as shown in Eq. (3).

$$c_s(\omega_s) = \frac{1}{1.06} \sqrt{\frac{2(\mu_1^2 + \omega_s^2 \mu_2^2)}{\rho(\mu_1 + \sqrt{\mu_1^2 + \omega_s^2 \mu_2^2})}} \quad (3)$$

Here, μ_1 is a shear modulus and μ_2 is a viscosity coefficient. In this experiment, phase velocity of surface wave was obtained from Eq. (1), and the shear moduli and viscosity coefficients were obtained from Eq. (3).

2.3 Estimation of viscoelastic parameters

An elastic phantom ($100 \times 100 \times 50 \text{ mm}^3$, Young's modulus: 30 kPa, OST) and a chicken wing were used as sample. Sine waves (100, 200, 300, 400 Hz, 3 waves, $104 V_{pp}$) were inputted to the piezoelectric actuator for excitation. For the detection of surface waves, A sine waves (1 MHz, 5 waves, PRF = 8 kHz, $124 V_{pp}$) were inputted to the airborne ultrasonic transducer. The reflected ultrasonic waves from the surface of the samples were received by an airborne ultrasonic transducer. The received signals were acquired using a data logger (MR6000, Hioki) at a sampling frequency of 50 MHz. The distances from the piezoelectric actuator to the ultrasonic transducer were set to 30, 31, 32, 33, and 34 mm. Displacements were calculated by conventional correlation calculation method.

3. Experimental results

Fig. 3 shows the calculated displacements at 30 and 34 mm when the excitation frequency was 200 Hz. Figure shows that three waves between 10 and 30 ms. **Fig. 4** shows the calculated phase for each position. **Fig. 5** shows the phase velocity of the surface wave obtained by substituting the inverse of the slope of **Fig. 4** into Eq. (1). When fitting was performed using **Fig. 5** and Eq. (3), viscoelasticity was estimated as $\mu_1 = 10.7 \text{ kPa}$ and $\mu_2 = 0.7 \text{ Pa}\cdot\text{s}$. Young's modulus was estimated to 32.1 kPa. From the estimated results, the error was 7% for the phantom Young's modulus of 30 kPa. The result shows that viscosity was small value, which agreed with the reference [3]. **Fig. 6** shows the phase velocity of the surface wave of the chicken sample. Viscoelasticity was estimated as $\mu_1 = 3.1 \text{ kPa}$ and $\mu_2 = 3.1 \text{ Pa}\cdot\text{s}$. Young's modulus was estimated to 9.3 kPa. The estimated viscosity coefficient of the chicken was higher than that of phantom.

4. Summary and future study

The viscoelasticity of the elastic phantom and chicken were successfully measured by the developed airborne ultrasonic Doppler system. For a future study, we will consider about non-contact vibration.

Acknowledgements

The authors are grateful to Japan Probe for about airborne ultrasonic transducers. The part of this work was supported by Ono

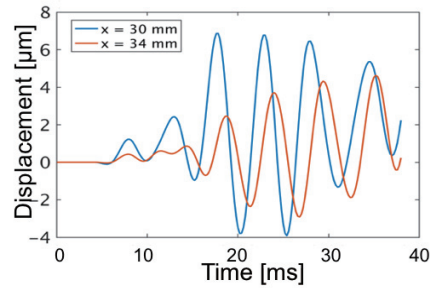

Fig. 3 Calculated displacements of surface wave.

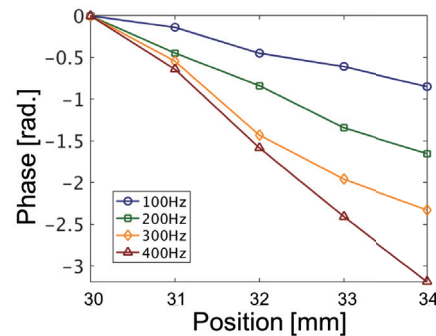

Fig. 4 Phase vs. position (phantom).

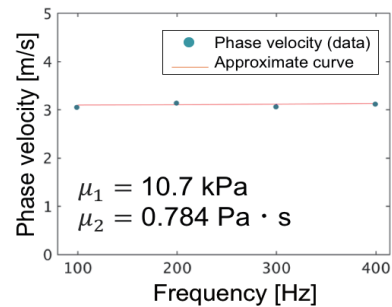

Fig. 5 Estimated phase velocity (phantom).

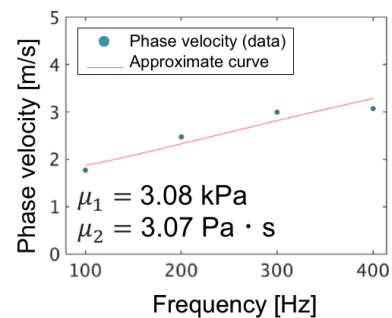

Fig. 6 Estimated phase velocity (chicken).

Acoustics Research Fund.

References

1. M. Tabaru and K. Nakamura: Proc. of ASJ spring meeting, (2015) 2 pages. [in Japanese]
2. Ł. Ambroziński, *et al.*: Scientific Reports **6** (2016) 11 pages.
3. S. Chen, *et al.*: J. Acoustic. Soc. Am., **115** (2004) 2781.
4. T. L. Szabo: *Diagnostic sound imaging: inside out* (Elsevier, MA, USA, 2014).