

## Comparison of vibrational displacements of piezoelectric devices with polished surface by laser speckle interferometer and laser Doppler vibrometer measurements

レーザスペックル干渉計とレーザドップラ振動計による圧電デバイス鏡面振動変位の比較

Jing Wang<sup>‡</sup>, Yasuaki Watanabe, Takayuki Sato

(Grad. School of system design , Tokyo Metropolitan Univ.)

王 景<sup>‡</sup>, 渡部 泰明, 佐藤 隆幸 (首都大学東京大学院 システムデザイン研究科)

### 1. Introduction

The Laser Speckle interference method is used to visualize the surface of a piezoelectric device, and various techniques are used<sup>(1)–(3)</sup>. In recent years, piezoelectric devices with mirror-finished surfaces enabled portable devices to operate at higher frequencies. For a quartz crystal resonator, for example, the interference method is used to test its polished surface for unevenness.

In past research, Laser Speckle interference was obtained by incidence at a 16-degree incidence angle using a red laser ( $\lambda = 630 \text{ nm}$ ) to accurately measure a polished surface<sup>(4)</sup>. However, it is not possible to make the incidence angle horizontal to measure in-plane vibrations. The technology to accurately measure for the pulse laser method the absolute vibrational displacement of Laser Speckles has not been studied, and it must be achieved during Laser Speckle interference.

In this study, we attempted to measure the absolute displacement of a polished surface using a laser Doppler vibrometer and "scan" the surface for laser speckle interference with an external ceramic resonator. A 377-nm ultraviolet laser was used as the laser speckle interferometer.

As a result, it was confirmed that the laser Doppler vibrometer and the laser speckle interferometer are related through image correlations.

### 2. Experimental system

**Fig. 1** shows our proposed measurement system. First, a glass-paneled device is installed as a substitution for piezoelectric material, and the center of the device is measured by a laser Doppler vibrometer. **Fig. 2** shows an outline of the measuring system in a block diagram with a 377-nm ultraviolet laser.

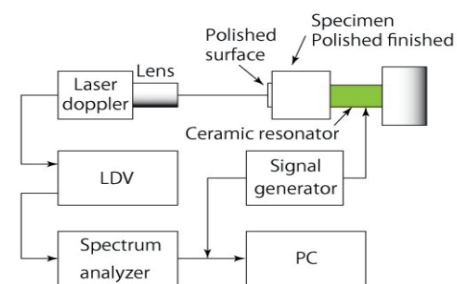

Fig.1. Laser Doppler vibration meter system

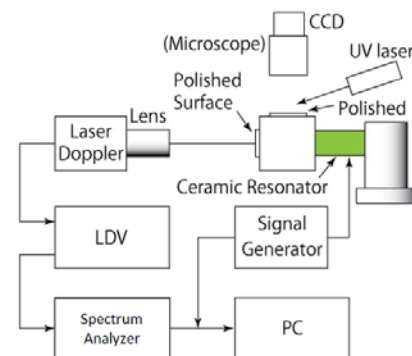

Fig.2. Laser speckle measuring system

A vibration device is observed by a CCD camera, and vibrate, multiplied by On and Off frequencies, and finally treated as an image correlation value. Formulas for obtaining the image correlation value are shown below and **Fig. 3** shows an example of the image correlation.

The image is generally calculated using reciprocals and are represented as white and black for parts that move and does not move, respectively<sup>(5)</sup>. A large part of the image is relatively equivalent to a slide vibration in a sample.

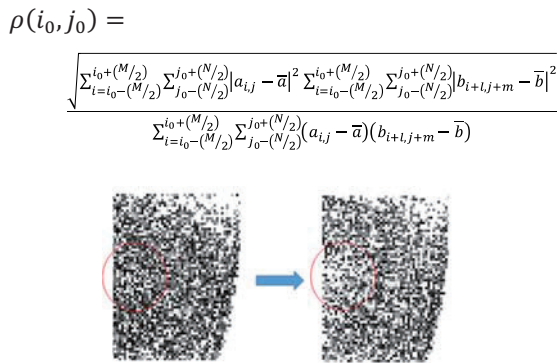

Fig. 3. Example of correlative image of speckle pattern.

### 3. Experimental results

The measurement results of the laser Doppler vibrometer are shown in **Fig. 4**. The horizontal axis is the signal generator voltage (V), and the vertical axis is the absolute displacement (nm). In the same figure, as regards the laser Doppler vibrometer, it is considered that a voltage of 0.005 V (5 mV) or less is effective for the piezoelectric vibrator because the maximum amplitude is 100 nm.

**Fig. 5** shows the measurement results of the mirror surface. In this case, the incident angle was 30.4 degree. The reason is that speckle interference has as much reflection as possible. The measured value is obtained 400 times and the average is obtained. **Fig. 6** was another sample showing that the incident angle was 5 degree for the pulse laser methods<sup>(6)</sup>.

From these **Fig. 4, 5 and 6**, it can be seen that the responses are close to the straight lines.

### 4. Conclusion

When this was simply considered for the Laser Speckle interferometer, it was predicted that the vibration displacement could be measured reliably although it was an average prediction. It wants to experiment successively in the future.

### Acknowledgment

I would like to express my deepest gratitude to Prof. Tagawa who offered to the laser Doppler vibrometer. This work was supported by Grant-in-Aid for Scientific Research 17k06466 in the Ministry of Education, Culture, Sports, Science and Technology.

### References

- (1) Y. Watanabe, et. al., Proc. of 15th European Frequency and Time Forum, Vol. CH2007, pp361-364, 2001.

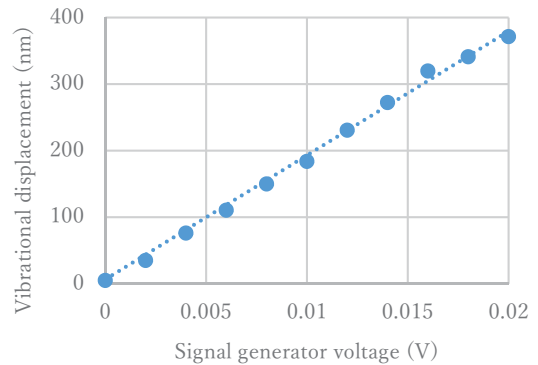

Fig. 4. Measurement results of LDV.

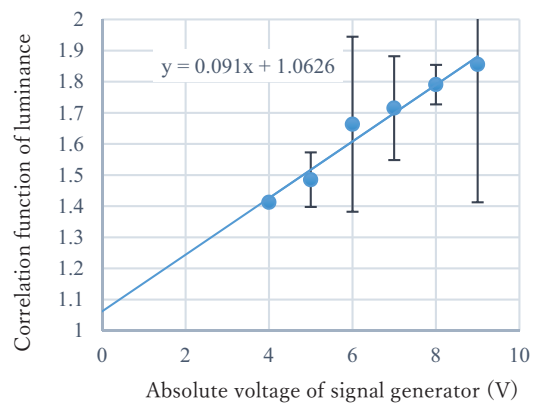

Fig. 5. Measured results of Laser Speckle method for polish surface.(30.4 degree)

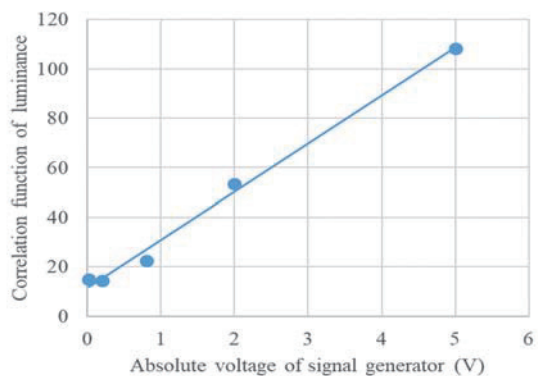

Fig. 6. Measured results of Laser Speckle method for pulse laser method. (5 degree)

- (2) Y. Watanabe, et. al., Jpn. J. Appl. Phys. Vol. 40, pp.3572-3574, 2001.
- (3) Y. Watanabe, et. al., Jpn. J. Appl. Phys. Vol. 41, Pt.1, No.5B, pp.3313-3315, 2002.
- (4) Y. Watanabe, et. al., IEEE Trans. Ultrason., Ferroelect., Freq. Contr., vol. 51, no. 5, pp. 491-495, 2004.
- (5) Jing Wang,, et. Al, JSAP Spring Meeting, 10p-PB1-6, (2019)
- (6) Y. Watanabe, et. al., Tech. rep. IEICE, 105, (2006, in Japanese)