

Vibration analysis of cantilever beam using impedance-loaded SAW sensor and finite element method

インピーダンス負荷 SAW センサと有限要素法を用いた片持ち梁の振動解析

Soya Shirai^{1†}, Jun Konndoh² (¹Shizuoka Univ; ²Shizuoka Univ)
白井聡也^{1†}, 近藤淳²(¹静大院 工,²静大院 工)

1. Introduction

In recent years, the aging of bridges and the like established during the high growth period has become a problem. Even a deteriorated bridge cannot be replaced immediately. Therefore, development of a health monitoring sensor that constantly monitors a deteriorated bridge is desired. We have proposed a new health monitoring sensor that combines a surface acoustic wave (SAW) device and a pressure sensor¹). Advantages of this sensor include that the sensor unit can operate without a power source, wireless measurement is possible, small size, and low cost. In this study, the vibration of a cantilever (PET resin plate) was measured using a 13.5 MHz SAW sensor. In addition, the change of vibration due to the position of the hole simulating damage was analyzed using the finite element method (Femtet), and compared with experimental and theoretical values.

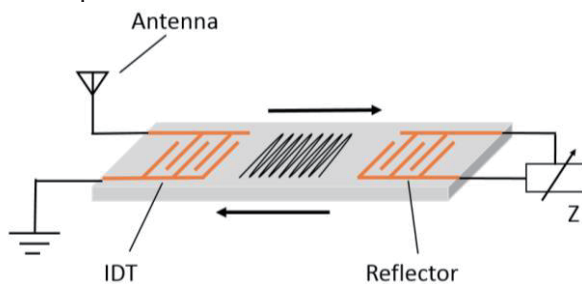

Fig. 1 SAW sensor

2. Operating principle of impedance load SAW sensor

Figure 1 shows a schematic diagram of the operating principle of the impedance load SAW sensor. When a high frequency signal is applied to the interdigital electrode (IDT) on the piezoelectric substrate, the SAW is excited. The SAW propagating on the piezoelectric substrate is reflected by the reflecting electrode and converted into a high frequency signal again by the input IDT. The characteristic of the reflected SAW depends on

the external impedance connected to the reflective electrode.

Therefore, the physical quantity can be measured from the reflection response by connecting the impedance change type sensor to the reflective electrode. In this study, a pressure sensor is connected to the reflector. Since the SAW reflection characteristics change as the capacitance of the pressure sensor changes due to strain, vibration measurement becomes possible.

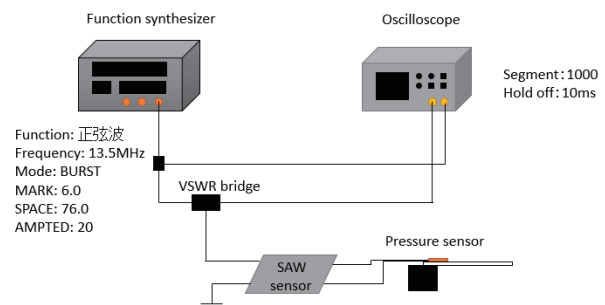

Fig. 2 Experimental system

3. Measurement system

Figure 2 shows a vibration measurement system for cantilever beams using a PET resin plate. A combination of a SAW sensor and a pressure sensor was used as a vibration sensor. The center frequency of the SAW sensor used in this study is 13.5 MHz. **Fig. 3** shows the model and the holes of the PET resin board used. During the vibration measurement, the PET resin plate was vibrated with a bending width from a horizontal state of 70 mm. A frequency characteristic can be obtained by recording a signal indicating the state of vibration for 10 seconds from the start of vibration with an oscilloscope and performing FFT (Fast Fourier Transform) on the attenuation waveform. The fundamental frequency was measured as one of the vibration evaluation parameters. The hole sizes were 2 mm and 5 mm, and the measurement was performed at the positions of 5 patterns of holes.

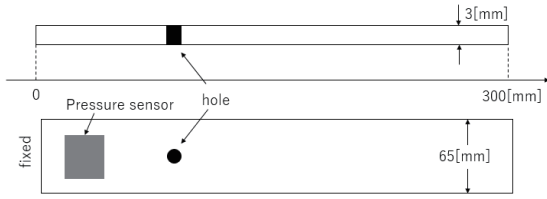

Fig. 3 PET resin plate model

4. Results and discussion

As vibration characteristics, natural frequency, second harmonic, peak ratio, and damping coefficient were measured. Typical results are shown in Fig. 4 for the natural frequency and Fig. 5 for the damping coefficient. Figure 4 shows that the natural frequency does not change much with the size and position of the hole. From Fig. 5, it can be seen that the attenuation coefficient increases as the position of the hole becomes farther from the fixed end. From this, it is considered that the attenuation coefficient is an important parameter for recognizing the position of the hole.

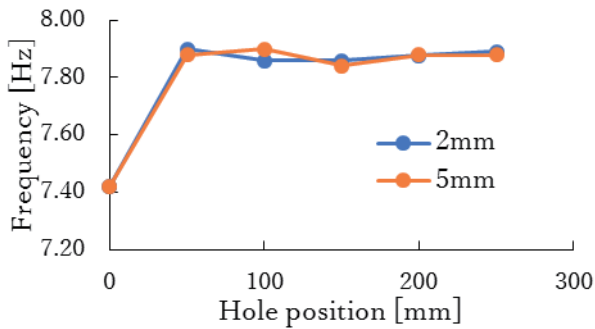

Fig. 4 Frequency result

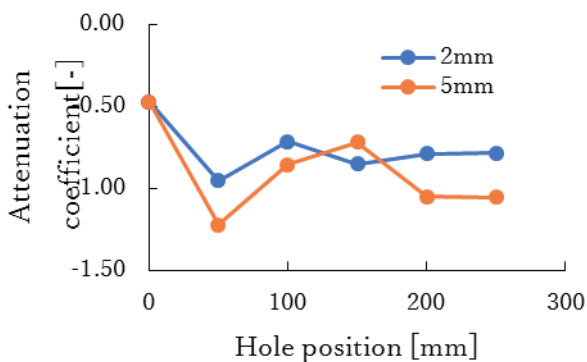

Fig. 5 Experiment result

5. Vibration analysis with finite element method

We have considered the natural frequency based on the measurements and theoretical values. In this study, the frequency change due to damage was analyzed using the finite element method (FEM).

Analysis conditions were set to be the same as the

measurement. Three types of damage (holes) with diameters of 0.1 mm, 1 mm, and 2 mm were provided at the same position as the measurement and analyzed, and the relationship between the damage position and vibration characteristics was investigated. To comparison with the measurement results, Figs. 6 and 7 show the natural frequency results of the analysis results and the damping coefficient results, respectively. From Fig. 6 it is found that the natural frequency does not change much regardless of the size and location of the hole. From Fig. 7, it can be seen that the attenuation coefficient becomes the lowest when the hole position is 100 mm, and becomes larger when it is far from the fixed end, regardless of the hole size. Those results suggest that the relationship between the hole position and the damping coefficient is important from the analysis results.

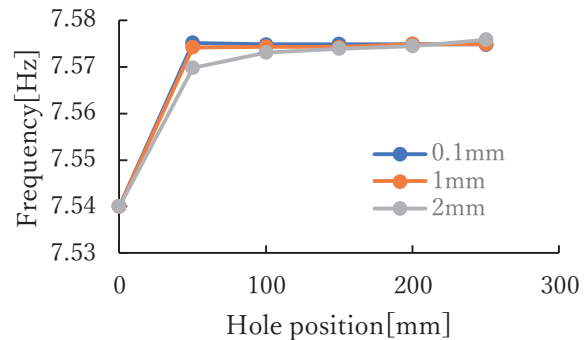

Fig. 6 Frequency analysis result

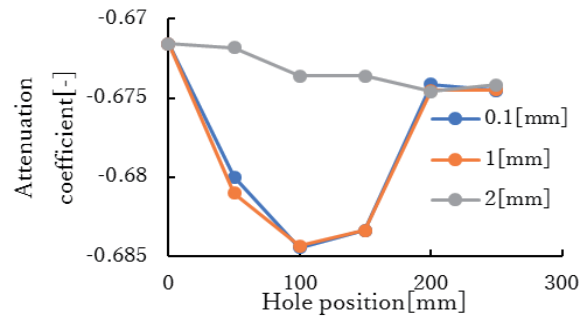

Fig. 7 Analysis result

6. Conclusion

The analysis results differed from the measured and theoretical values. This is because the number of meshes, attenuation coefficient, and other parameters are different from the measurement. However, since the attenuation coefficient changes depending on the position of the hole, it is considered an important parameter in measurement and analysis.

References

1. M. Oishi, et al., Jpn. J. Appl. Phys., 55 07KD06 (2016).