

Study on physical modeling of heat phase adjuster in loop-tube type thermoacoustic system

ループ管型熱音響システムにおける

Heat phase adjuster の物理モデル化の検討

Kazuki Shiraki^{1†}, Shin-ichi Sakamoto², Yuya Kurata¹, Yuto Kawashima¹, Riku Onishi¹, and Yoshiaki Watanabe³ (¹Doshisha Univ.; ²Univ. of Shiga Pref.)

白木一希^{1†}, 坂本真一², 倉田侑弥¹, 川島裕斗¹, 大西陸¹, 渡辺好章¹(¹同志社大,²滋賀県立大)

1. Introduction

Among the difficulties to realize a loop-tube type thermoacoustic system, there is the instability of the resonance mode as well as its low efficiency of the system. In order to solve these issues, heat phase adjuster (HPA) has been proposed.^[1,2] HPA is a technique to control the sound field by making a local hot region. However the control of the resonance mode is still unclear. In this paper, the physical model for HPA is developed. Using the model, the sound field in the acoustic tube changing with the position of HPA is analyzed. The experimentally measured resonance mode of the loop-tube is also compared with the analytical result.

2. Physical Model for HPA

Considering the complex reflection coefficient of the sound pressure at HPA, the physical model that consists of a circular tube with a sectional area A involving a locally hot region is developed. Neglecting viscosity in the fluid, the sound wave is assumed as a plane wave travelling in the axial direction. The physical model for HPA is illustrated in Fig. 1. Neglecting heat diffusion to the neighbors, only the length d of HPA is assumed to be set at high temperature. The acoustic impedance is Z at the normal temperature portion and Z_{HPA} in HPA. The sound pressures at two boundaries named Borders 1 and 2 are P_1 and P_2 , respectively. The incidence, reflected and transmitted waves at HPA are denoted by P_i , P_R and P_T . By rewriting P_1 , P_2 with P_i , P_R and P_T , the transmission matrix of HPA is given as^[3]

$$\begin{bmatrix} P_1 + P_R \\ \frac{A}{Z}(P_1 - P_R) \end{bmatrix} = \begin{bmatrix} \cos kd & j \frac{Z_{\text{HPA}}}{A} \sin kd \\ j \frac{A}{Z_{\text{HPA}}} \sin kd & \cos kd \end{bmatrix} \begin{bmatrix} P_T \\ \frac{A}{Z} P_T \end{bmatrix}, \quad (1)$$

where k is the wavenumber ω/c . As an example, the complex reflection coefficient Γ_{11} of the sound pressure at the left end of HPA can be obtained from Eq.(1) as^[3,4]

$$\Gamma_{11} = -\frac{(Z_{\text{HPA}}^2 - Z^2)(e^{2jkd} - 1)}{(Z_{\text{HPA}} + Z)^2 e^{2jkd} - (Z_{\text{HPA}} - Z)^2} e^{j\theta}, \quad (2)$$

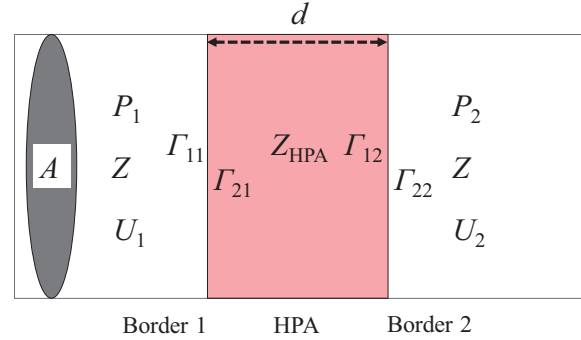

Fig. 1 Physical model for HPA.

$$\theta = 4\pi \left(\frac{x}{\lambda} - \frac{1}{4} \right), \quad (3)$$

where x is the distance from the sound source. Other reflection coefficients Γ_{22} , Γ_{12} and Γ_{21} are similarly derived as Eqs. (2) and (3). In the sound field of HPA, three waves are considered at hand, corresponding to the incidence wave P_0 ; wave #1 reflected at Border 1, wave #2 transmitted through Border 1 after transmitting through Border 1 and reflecting at Border 2, and wave #3 transmitted through Borders 1 and 2. Further, the incidence wave to other side of HPA is similarly considered. Six waves in total are calculated using Γ_{ij} ($i, j=1, 2$). The phase shift of the synthetic wave from the incidence wave is evaluated. The calculation conditions are as follows; the total length of 3300 mm, the inner diameter of 42 mm, the working fluid of atmospheric air, and the frequencies of 1st to 3rd resonances. HPA with a 30 mm length heated at 473 K is set in the range of 1-3300 mm from the sound source.

The phase shift ϕ of the synthetic wave from the incidence wave on HPA is shown in Fig. 2. When ϕ vanishes, a sound wave is supposed to be excited in the positive direction. In contrast, the sound wave in the negative direction is excited for ϕ of 180° . The analytical result of the relation between the HPA position and the direction of sound wave is listed in Table 1. The symbols + and - represent the positive and negative directions, respectively. By setting HPA within the realm of + shown in the table, the resonance mode of the loop tube is supposed to be controllable.

3. Experiment on Resonance Mode Control

Figure 3 shows the experimental system using a loop tube with a 3300 mm total length and a 43 mm inner diameter. Atmospheric air is used for the working fluid. A prime mover (PM) or a loud speaker is employed for the sound source. The temperature gradient is formed in PM by supplying a 330 W electric power to the hot-end heater and circulating 20°C water at the cold end. The driving frequency of the loud speaker is 106, 214 or 322 Hz. The input level is adjusted so that the amplitude of the sound pressure in the tube becomes 800 Pa. The position x of HPA with a 30 mm length is changed to 2100, 2650 or 2950 mm while keeping the input power of 80 W. After measuring the sound field in the tube using the sound source of PM, the forced-vibration experiment is conducted using the loud speaker. Changing the driving frequency in 3 ways for each case of the HPA position, the sound field is measured for 9 cases in total.

The measured resonance mode in the loop tube using HPA is shown in Table 2. By setting HPA within the realm of + in Table 1, the resonance mode is confirmed to be controllable. Examples of acoustic intensity in the tube obtained by the forced vibration are shown in Fig. 4. It is seen that only the sound wave of the objective resonance mode propagates in the positive direction. The same trend is also confirmed in other conditions. Therefore, it is assumed that HPA controls the resonance mode by letting the specific sound wave propagate in the positive direction.

4. Conclusion

In order to discuss the contributing factor in the control of the resonance mode by HPA, the development of the physical model of HPA was attempted. It was confirmed that the analytical result by the physical model agrees with the experimental result for the resonance mode of the loop tube using HPA. Furthermore, it was supposed that HPA controls the resonance mode by letting the sound wave specified by the setting position propagate in the positive direction. More detailed physical modelization to simulate the temperature gradient will be attempted hereafter.

Acknowledgment

This work was partly supported by JSPS grants-in-aid for young scientists (A) and (B), JSPS grant-in-aid for challenging exploratory research, grant-in-aid for scientific research (C), program for fostering regional innovation and JST super cluster program.

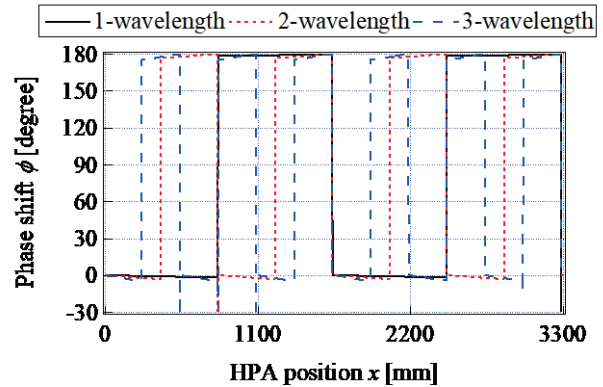

Fig. 2 Phase shift ϕ of synthetic wave.

Table 1 Relation between ϕ and HPA position.

HPA position [mm]		1-wavelength	2-wavelength	3-wavelength
397-536	2048-2185	+	-	-
810-1085	2461-2736	-	+	-
1223-1359	2873-3009	-	-	+

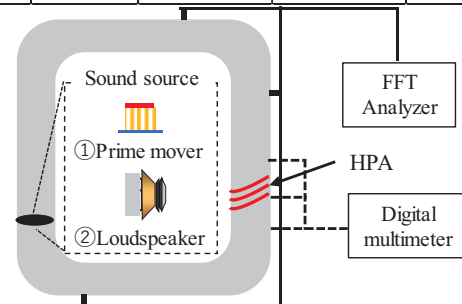

Fig. 3 Experimental setup.

Table 2 Resonance mode in loop-tube using HPA.

Resonance mode	HPA position [mm]
1-wavelength	400, 500, 2100, 2200
2-wavelength	1000, 2650
3-wavelength	1300, 2950

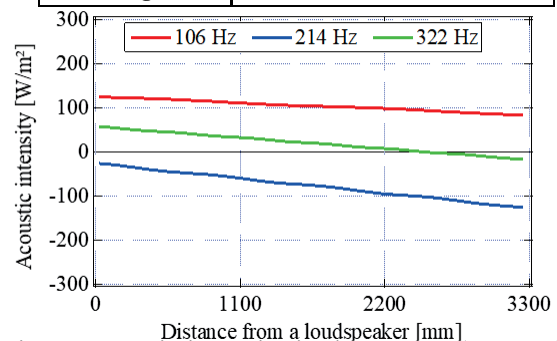

Fig. 4 Acoustic intensity in the system ($x=2100$).

References

1. A. Kido, S. Sakamoto, K. Taga and Y. Watanabe: Jpn. J. Appl. Phys. Vol. 5, No.7S1,07KE14 (2016).
2. K. Shiraki, S. Sakamoto and Y. Watanabe: Jpn. J. Appl. Phys. Vol. 58, No. SG, SGGD16 (2019).
3. K. Shiraki, S. Sakamoto, Y. Kawashima, R. Onishi and Y. Watanabe: Reports of the autumn meeting the Acoustical Society of Japan (2019) (to be published). [in Japanese].
4. H. Sasao, Trans. SHASE Vol. 81, pp.51-58 (2007). [in Japanese].