

Study of an acoustic field in microchannel

マイクロ流路中での超音波音場の検討

Teruyuki Kozuka^{1†}, Kyuichi Yasui¹, Shinichi Hatanaka², Toru Tuziuti¹, Judy Lee¹ and Atsuya Towata¹ (¹AIST; ²UEC)

小塚晃透^{1‡}, 安井久一¹, 畑中信一², 辻内亨¹, リイ・ジュディ¹, 砥綿篤哉¹ (¹産総研; ²電通大)

1. Introduction

Recently, noncontact micro manipulation technique is needed micromachine technology, biotechnology and so on. The radiation pressure of ultrasound may be used for this purpose as it is possible to trap particles at sound pressure nodes of the standing wave field in the medium. The authors have realized an acoustic manipulation technique to transport particles three-dimensionally using a standing wave field generated by four transducers in water[1,2].

However, when this technique is to be applied in industry, the surrounding environment is not necessarily free without obstacles, but occasionally restricted with solid walls. Manneberg *et al.* [3] have studied manipulation of bio cells in the microchannel on the glass plate irradiated with ultrasound through a metal block. Masuda *et al.* [4] have tried to control a microbubble flow in blood vessel using acoustic radiation pressure.

In the present paper, a sound wave is generated by a transducer in water, and a glass plate with a microchannel is set on the liquid surface in the water tank. The sound wave should be transmitted into the microchannel through the glass plate. In the experiment, when the liquid water containing alumina particles was injected into the microchannel, the particles flowed along several layers. It was shown that the traveling wave was transmitted into the microchannel and the standing wave field was formed in the microchannel.

2. Experiment

Figure 1 shows a glass plate with a microchannel. The size of the glass plate is 50mm × 50mm × 5mm. A microchannel of 1mm × 1mm was made at the center of the plate. The microchannel is surrounded by three glass walls, and the top surface is open to air. The experimental apparatus is shown in **Fig. 2**. The glass plate is floated at the water surface of the water tank. The transducer on the bottom of the water tank is set at 30 degrees from the horizontal direction. The sound beam is directed into the microchannel on the glass plate.

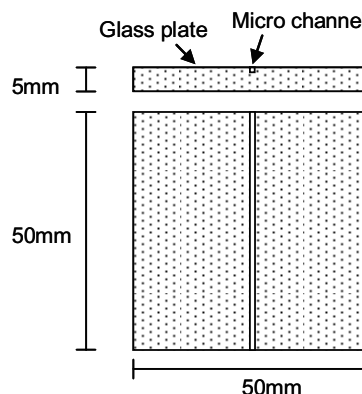

Fig.1 Glass plate with micro channel

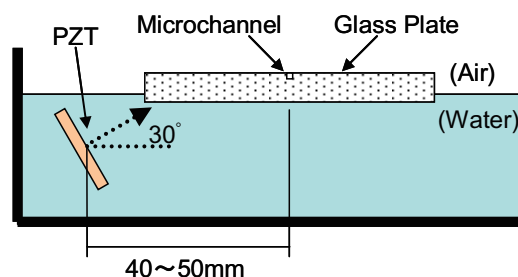

Fig.2 Experimental apparatus

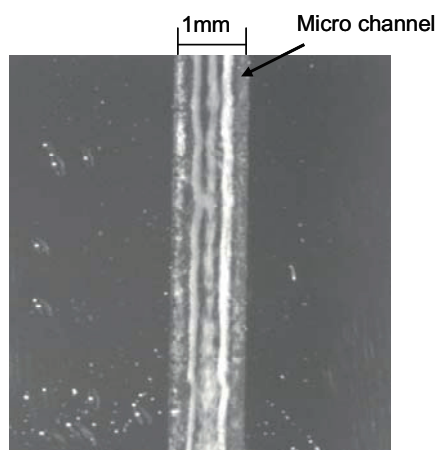

Fig.3 Agglomerated particles in microchannel

When the suspension of the alumina particles was flowed into the microchannel by a pipette, the alumina particles were agglomerated along a few layers as shown in **Fig. 3**. The half wavelength is 0.625 mm when the frequency is 2.4 MHz and the sound speed is 1500 m/s in water. The experimental

Email: kozuka-t@aist.go.jp

result in Fig. 3 indicates 3 or 4 layers, which is consistent with the above estimation.

In the next experiment, the transducer was directly attached to the glass plate without water. The size of the transducer is 30mm×5mm and the driving frequency is 4.0 MHz. In order to attach the transducer to the glass plate without a gas layer, it was coated with grease. As in the case of Fig. 3, several layers of alumina particles were successfully observed in this case, which indicates the formation of a standing wave in a microchannel.

3. Discussion

At first, we will consider the propagation of the sound wave through the water in a water tank. According to the Snell's law, the propagation of sound waves from medium I to medium II is expressed by the following formula.

$$\frac{\sin \theta_t}{\sin \theta_i} = \frac{c_2}{c_1} \quad (1)$$

Where θ_i is incidence angle to the boundary surface, θ_t is refraction angle from the boundary surface, c_1 is sound speed in medium I, c_2 is sound speed in medium II. When a sound wave propagates through a glass plate from water in a water tank, the incidence angle to the bottom surface or the side surface of the glass plate is 60 degrees or 30 degrees, respectively. The speed of sound in water is $c_1=1500\text{m/s}$, and that in the glass plate is $c_2=5440\text{m/s}$. The incidence angle θ_i must be less than 16 degrees so that the formula (1) is satisfied. In the present case, however, all the sound wave should be reflected.

The real sound source is finite, and the radiated sound is not an ideal plane wave. Thus, the numerical calculation using the finite element method (FEM) is necessary. However, it is not possible to perform it at present because of too heavy calculations.

On the boundary surface between different materials, a part of the sound wave is transmitted, and the other part is reflected. When a sound wave is incident on the interface vertically, transmissivity α and reflectance r are estimated by the following formulas using ρ .

$$r = \left(\frac{\rho_1 c_1 - \rho_2 c_2}{\rho_1 c_1 + \rho_2 c_2} \right)^2 \quad (2), \quad \alpha = 1 - r \quad (3)$$

Where ρ_1 and ρ_2 are density of medium I and medium II, respectively. When $\rho_1=1000 \text{ kg/m}^3$ in water and $\rho_2=2420 \text{ kg/m}^3$ in glass, $\alpha=0.64$ and $r=0.36$. **Figure 4** shows the conversion of the acoustic intensity through the boundaries when the initial intensity in water tank is one. In the microchannel, the intensity of the incident wave is

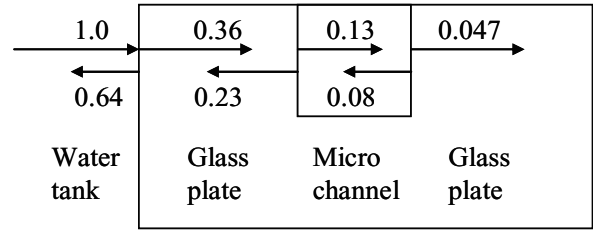

Fig.4 Sound intensity on the sound road.

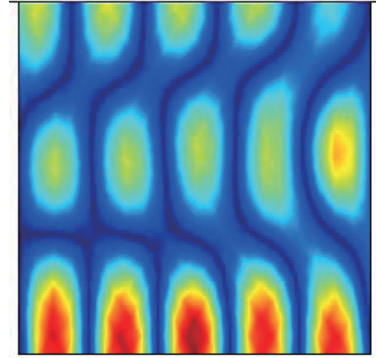

Fig.5 Numerical calculated sound pressure

0.13 and that of the reflected wave is 0.08. Thus, a partially standing wave field is formed in the microchannel.

With regard to the case of the direct contact of the PZT transducer to the glass plate, it is possible to calculate the sound pressure distribution by the finite element method (COMSOL Multiphysics). **Figure 5** shows the calculated sound-pressure distribution at the cross-section of the microchannel. It is seen that a standing wave field is formed in the microchannel although its structure is rather complex.

4. Conclusion

A standing wave field was formed in the microchannel of the 1 mm x 1mm in cross section on the glass plate. The transducer on the bottom of the water tank was set at the angle of 30 degrees relative to the horizontal direction. The sound beam propagates into the microchannel and a standing wave field was formed in it. Alumina particles flowed along several layers in the microchannel due to the radiation force of ultrasound.

Acknowledgment

This work was supported by KAKENHI21560254.

References

1. T.Kozuka et.al.: Jpn.J.Appl.Phys. **47**(2008) 4336.
2. T. Kozuka et.al.: Jpn. J. Appl. Phys. **48** (2009) 07GM09.
3. O.Manneberg et. al.: Ultrasonics **49** (2009) 112.
4. K. Masuda et. Al.: Jpn J. Appl. Phys. **48** (2009) 07GK03.