

Evaluation of Ultrasonic Attenuation in Oxide Thin Films Using Brillouin Oscillations Excited by Wavelength-Tunable Picosecond Ultrasound

波長可変ピコ秒超音波法による酸化物薄膜の減衰評価

Kei Morita[‡], Hirotsugu Ogi, Nobutomo Nakamura and Masahiko Hirao (Graduate School of Engineering Science, Osaka University)

森田啓[‡], 萩博次, 中村暢伴, 平尾雅彦 (大阪大学大学院基礎工学研究科)

1. Introduction

Surface acoustic wave (SAW) filters have been widely used in telecommunication devices such as mobile phones and wireless local area networks. Recently, their operating frequencies increase to compensate for the lack of frequency channels. Higher frequency acoustic filters, including bulk acoustic wave (BAW) filters, are then intensively studied. It is required to use less lossy thin films for the BAW filters, because high frequency bulk waves (~10 GHz) propagate in the thin films. Metallic thin films are undesirable because of the scattering loss at grain boundaries.

Amorphous thin films are therefore promising. Especially, the amorphous oxide thin films are important candidate materials because they are effectively deposited by a reactive sputtering method. Their acoustic properties such as sound velocity and attenuation are then needed for designing the BAW devices. The sound velocity has been evaluated accurately using Brillouin oscillations excited by picosecond ultrasounds¹. However, it has never been straightforward to characterize attenuation. Emery and Devos² proposed a methodology for evaluating the oxide thin-film attenuation using Brillouin oscillations in the Si substrate. However, this method needs several specimens with different thicknesses of the thin film. Also, the intensity of Brillouin oscillations in the Si substrate is highly affected by the thin film thickness, deteriorating the accuracy of the attenuation measurement using different thickness specimens¹.

From these backgrounds, we present a novel methodology for evaluating attenuation of the amorphous oxide thin films using Brillouin oscillations in the Si substrate detected by the wavelength-tunable picosecond laser ultrasound technique. This method uses the high sensitivity of the refractive index in Si to the wavelength near 400 nm, which allows to evaluate the frequency dependence of attenuation in a wide frequency range.

2. Brillouin oscillations

The pump-probe picosecond ultrasound method has been developed by Thomsen *et al.*^{3,4}. Irradiation of the thin film with the ultrafast light pulse causes a coherent acoustic pulse, which propagates in the film thickness direction. The delayed probe light pulse is then introduced to detect the acoustic waves through the reflectivity change. For transparent and translucent materials, the probe light pulse is diffracted by the acoustic wave in the film, causing oscillation in the reflectivity change of the probe light. This is called Brillouin oscillation, and its oscillation frequency f can be used to extract the sound velocity v via Bragg's condition

$$f = \frac{2nv}{\lambda}, \quad (1)$$

where n and λ denote the refractive index of the examined material and the wavelength of the probe light in vacuum, respectively. We have assumed the frequency dependence of the attenuation coefficient¹ α as

$$\alpha(\omega) = \beta\omega^2 + \gamma\omega^4. \quad (2)$$

The ω^2 term represents the absorption loss caused by the phonon-phonon relaxation process (Akhieser's relationship)⁵, and the ω^4 term indicates the scattering loss by defects. The nondefective structures ($\gamma=0$) are made possible by controlling the deposition condition¹, and it is important to determine the β value.

The effective method to evaluate the β value is to measure the frequency dependence of attenuation. We then focus the high sensitivity of the refractive index of Si to the wavelength of the probe light. As seen in Eq. (1), the Brillouin oscillation frequency, which is equal to the detectable sound-wave frequency, is proportional to n , and n varies between 5.5 and 6.7, corresponding to the frequency change of 235 and 300 GHz. Thus, by changing the wavelength of the probe light, we can evaluate the frequency dependence of attenuation and then the β value in oxide thin films.

ogi@me.es.osaka-u.ac.jp

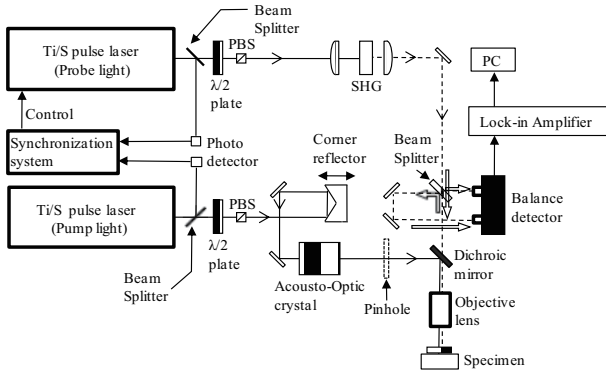

Fig. 1 Schematic of the optics we developed. Dashed lines show the probe beam (wavelength $\lambda = 400\text{-}375$ nm). Solid lines show the pump beam ($\lambda = 800$ nm).

3. Experiments

We deposited silica thin films on the (001) surface of the Si substrate using a DC reactive sputtering method. The film thickness was 569 nm. The target was Si, and the gas was a mixture of Ar and O₂. The specimen was covered with a 10 nm Al thin film as a transducer material of the acoustic pulse.

The schematic of the optical system we developed is shown in Fig. 1. We used two mode-locking titanium-sapphire pulse lasers with 100 fs pulse width and 80 MHz repetition frequency. One was used as the pump light and focused on the aluminum film to generate the acoustic pulse through thermal expansion. The other was wavelength-tunable (750-800 nm wavelength) and frequency doubled (375-400 nm wavelength) and irradiated the specimen as the probe light to detect the reflectivity change. Both pump and probe light pulses were perpendicularly focused on the specimen surface. We synchronized these two pulse lasers within the jittering of 50 fs by the synchronization system. Thus, this system allows to change only the probe-pulse wavelength, remaining all properties of the pump light pulse unchanged. We can therefore detect the Brillouin oscillations with various wavelength for the same sound-wave filed.

We measured Brillouin oscillations in the oxide film and the Si substrate with the wavelength range between 400 and 375 nm. Then, the theoretical calculation was fitted to the measured refractivity responses with variable parameter of the β value.

4. Results and Discussion

The solid lines in Fig. 2 show the typical Brillouin oscillations measured by the wavelength tunable pump-probe system. They consist of the low-frequency and high-frequency Brillouin oscillations, corresponding to the diffraction of the probe light by the sound wave in the SiO₂ film and

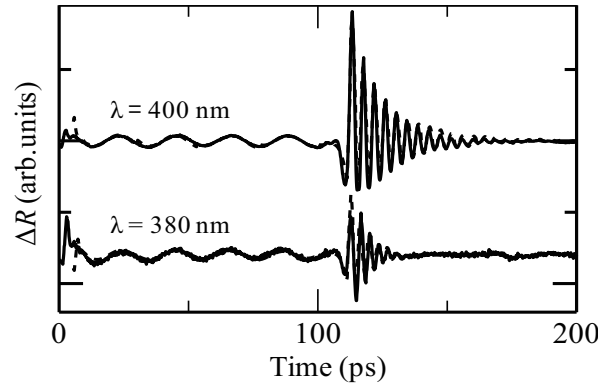

Fig. 2 Measured (solid lines) and calculated (broken lines) Brillouin oscillations of the SiO₂/Si specimen obtained by different probe light wavelengths.

in the Si substrate, respectively.

We constructed the numerical simulation of the reflectivity change including the β value as the fitting parameter. The other parameters were determined by fitting the simulation to the measurement at the wavelength of 400 nm. The results are shown in Fig. 2 by broken lines, showing good agreement with the measurements. The determined β value was $7.0 \times 10^{-3} \text{ nm}^{-1} \text{ THz}^{-2}$, which was significantly larger than the previously reported value² by $1.3 \times 10^{-3} \text{ nm}^{-1} \text{ THz}^{-2}$.

References

1. H.Ogi, T. Shagawa, N. Nakamura, and M. Hirao, Phys. Rev. B **78**, 134204 (2008).
2. P. Emery, A. Devos, Appl. Phys. Lett. **89**, 191904 (2006)
3. C. Thomsen, J. Strait, Z. Vardeny, H. J. Maris, and J. Tauc, Phys. Rev. Lett. **53**, 989 (1984).
4. C. Thomsen, H. T. Maris, and J. Tauc, Phys. Rev. B **34**, 4129 (1986).
5. W. Mason, Physical Acoustics, Vol. 3 (Academic, New York, 1965).