

Vibrations of nanostructures probed by ultrashort optical pulses

超短光パルスによるナノ構造の振動研究

Hiroataka Sakuma^{1‡}, Motonobu Tomoda¹, Osamu Matsuda¹, Takashi Fukui²,
Katsuhiko Tomioka² and Oliver B. Wright¹ (¹Grad. Sch. Eng., Hokkaido Univ.;
²Grad. Sch. Info. and RCIQE, Hokkaido Univ.)

佐久間洋宇^{1‡}, 友田基信¹, 松田理¹, 福井孝志², 富岡克広², Oliver B. Wright¹
(¹北大院工 ; ²北大院情報及び量集センター)

1. Introduction

Vibrations in nanostructures are conveniently investigated using ultrafast optical techniques. Past studies concern the observation of individual modes of various nanostructures: nanocubes [1,2], nanodiscs [3], nanorods [4,5], and collective modes of two-dimensional periodic structures [2].

We have been investigating vibrations of GaAs nanopillars of hexagonal cross section on a GaAs substrate using an ultrafast optical pump-probe technique. This work was presented in this symposium last year [6]. We reported the frequencies, the attenuation, and the phase of the dominant mode (breathing mode). Moreover, we observed Brillouin oscillations originating in the substrate. However, we could not interpret all the observed vibrational frequencies.

To clarify these frequencies we have modified the angle of incidence of the pump from vertical to oblique in order to investigate the effect on the excited modes. In addition we investigate the effect of the pump polarization and direction of incidence with respect to the crystal axes.

2. Samples

GaAs nanopillars are prepared on a GaAs (111)B substrate by SA-MOVPE (selective-area metallorganic vapor phase epitaxy) [7], as shown in **Fig. 1**. They have diameter 100-400 nm, height 200-800 nm, period 200-2000 nm, and triangular lattice periodicity. The sizes are estimated from scanning electron microscope images.

3. Experimental setup

The experimental setup is shown on **Fig. 2**. We use an ultrafast optical pump-probe technique with a mode-locked Ti:Sapphire laser of central wavelength 830 nm, pulse

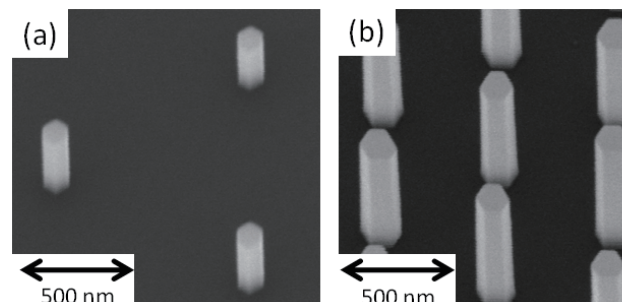

Fig. 1 (a), (b) Typical scanning electron microscope images of GaAs nanopillars.

duration ~ 200 fs, and repetition rate 80 MHz (period 12.5 ns). The laser beam is divided into two, one for probe light and another for pump light. An acousto-optic modulator (AOM) is used to chop the pump beam.

The pump beam (415 nm) is focused to a ~ 20 μm diameter spot on the sample at 60° incidence using a single lens. This pump pulse generates vibrations of the nanopillars at frequencies up to ~ 50 GHz, the strain originating from thermoelastic and deformation potential mechanisms. The probe beam (830 nm) passes through a variable delay line, and is focused on the sample to a ~ 20 μm diameter spot using a single lens in order to monitor the reflectivity changes. All the experiments are performed at the room temperature.

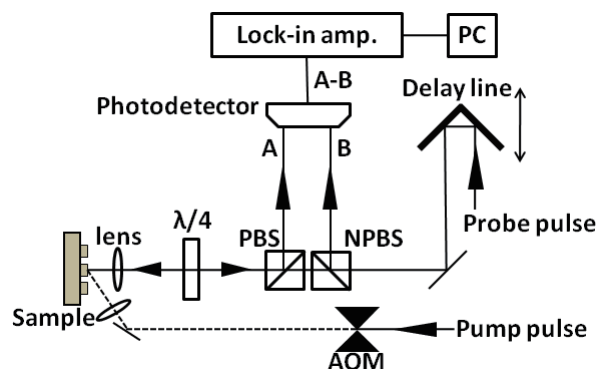

Fig. 2 Experimental setup for generation and detection of nanopillar vibrations. AOM: acousto-optic modulator, PBS: polarizing beam splitter, NPBS: non-polarizing beam splitter, $\lambda/4$: quarter-wave plate, PC: personal computer.

loghiro@eng.hokudai.ac.jp

4. Results and discussion

We obtained data from 14 kinds of nanopillar. A typical experimental result for the relative reflectance change is shown in **Fig. 3**. The amplitudes of the Fourier spectra of the transients in Fig. 3 are shown in **Fig. 4**, showing peaks near 10 GHz and 48 GHz. The peak at 10 GHz indicates the main vibrational mode of the pillars. The peak at 48 GHz corresponds to Brillouin oscillations [6].

We first introduce the main vibrational mode (breathing mode). We plot such dominant frequencies from each sample in **Fig. 5**. The thickness D is defined in the inset of Fig. 5. The frequencies are inversely proportional to D . This indicates that this vibrational mode is indeed a breathing mode. By approximating the pillar cross-section to a circle, the frequency of this mode can be estimated as

$$f_{br}^{(n)} = \frac{\tau_n}{2\pi r} v_l, \quad (1)$$

$$\tau J_0(\tau) = \frac{1-2\nu}{1-\nu} J_1(\tau), \quad (2)$$

where τ_n is the n -th root of the eigenvalue equation (2), v_l is the average longitudinal sound velocity for propagation in the (111) plane, r is the radius, ν is Poisson's ratio and J_n is the n -th Bessel function of the first kind [5]. We detect an attenuation rate for this mode equal to 0.01 ps^{-1} , approximately independent of the size of the pillars. The vibrational phase is consistent with a cosine variation.

We compared the results of vertical pump beam incidence and oblique incidence. We found that some resonance peaks for vertical incidence become stronger than those for oblique incidence in some samples (such as the 6 GHz and 12 GHz peaks in Fig. 4). In addition, we found the results to be almost independent of pump polarization, and a negligible difference in reflectivity variation when comparing pump excitation from the directions (a) and (b) in the Fig. 5 inset was observed.

5. Conclusion

We have investigated the vibrational modes of GaAs nanopillars of hexagonal cross section on a GaAs substrate using an ultrafast optical pump-probe technique. Breathing modes of the pillars are detected in the 10-30 GHz range.

With oblique excitation some non-breathing modes are more weakly generated. We plan to

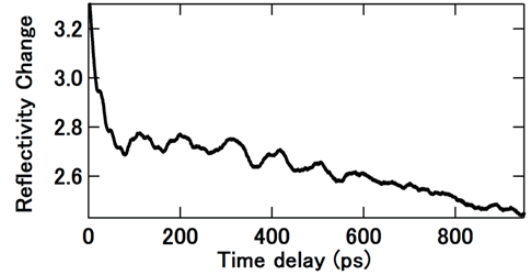

Fig. 3 Relative reflectivity change versus the time delay between the pump and the probe pulses. The nanopillar has a height of 270 nm, a width of 350 nm and distance of between nanopillars 1000 nm. Oblique pump incidence.

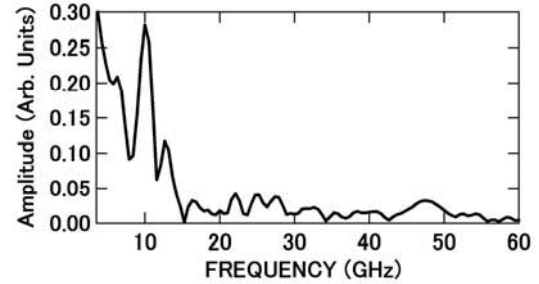

Fig. 4 Vibrational amplitude spectrum obtained from the modulus of the Fourier transform of the data in Fig. 3.

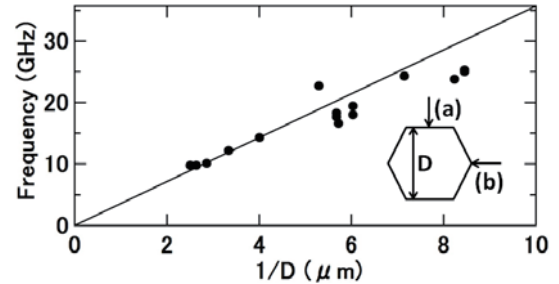

Fig. 5 The solid line is a theoretical value given by eq. (1) (fundamental mode). Black circles are peak frequencies from each Fourier Amplitude. Inset: pillar section and definition of D .

use the finite element method to analyze the vibrational modes of the pillars and to better understand the effect of changing the pump incidence angle.

References

1. H. Petrova *et al.*: *J. Chem. Phys.* **126** (2007) 094709.
2. J. F. Robillard *et al.*: *Phys. Rev. B* **76** (2007) 092301.
3. C. Giannetti *et al.*: *Phys. Rev. B* **76** (2007) 125301.
4. G. M. Sando *et al.*: *J. Chem. Phys.* **127** (2007) 074705.
5. M. Hu *et al.*: *J. Am. Chem. Soc.* **125** (2003) 14925.
6. 佐久間洋宇 他: 超音波テクノ 2009年9,10月号 (掲載予定)
7. J. Motohisa *et al.*: *Physica E* **23** (2004) 298.