

High Efficient Optical Mode Converter Using Lamb Wave ラム波を用いた高効率なモード変換器

Koki Saito[†], Yasuhiko Nakagawa and Shoji Kakio(Univ. of Yamanashi)
齋藤光希[‡], 中川恭彦, 垣尾省司 (山梨大院・医工)

1. Introduction

With the advancement of information networks, radio waves have recently been used for various purposes in every field. The miniaturization and sophistication of any device for communication signal processing are carried out. Lamb wave devices are examples of such devices and in this study, we focus our attention on a compact, lightweight, and low-loss Lamb wave-type device.

In this study, with the aim of propagating the Lamb wave crystal substrate in optical communications, we theoretically and experimentally examined light-wave propagation in a crystal in which Lamb waves^{1,2,3,4,5} had caused cyclic variations in the refractive index in order to inquest a high-efficiency mode converter.

2. Periodical Variation in Refractive Index Caused by Lamb Waves

The coordinate system used for the analysis of the Lamb wave is shown in Fig. 1. For the purpose of analyzing wave motions, the X_1 direction was assumed as the Lamb wave's propagation direction, the X_3 direction was assumed as the direction vertical to the surface of the substrate, λ was assumed as the Lamb wavelength, and H was assumed as the substrate's thickness. The analysis of waves in piezoelectric media must satisfy a piezoelectric basic formula, i.e., Equation (1) or the equation of motion and Equation (2) or Laplace equation.

$$\rho \frac{\partial^2 u_j}{\partial t^2} = c_{ijkl}^E \frac{\partial^2 u_k}{\partial x_i \partial x_l} + e_{kij} \frac{\partial^2 \phi}{\partial x_i \partial x_k} \quad (1)$$

$$e_{ikl} \frac{\partial^2 u_k}{\partial x_i \partial x_l} - \varepsilon_{ik}^S \frac{\partial^2 \phi}{\partial x_i \partial x_k} = 0 \quad (2)$$

u : Particle displacement, ϕ : Potential

ρ : Medium density, c_{ijkl}^E : Elastic constant tensor

e : Piezoelectric constant tensor, ε^S : Dielectric constant tensor

nakagawa@es.yamanashi.ac.jp

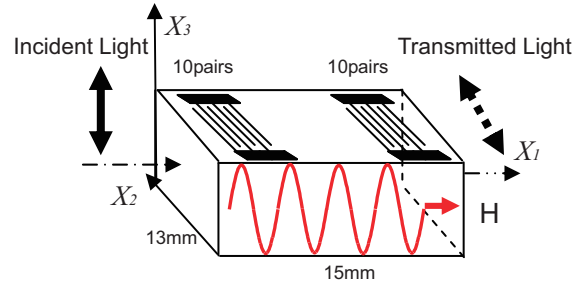

Fig.1 Optical mode converter overview.

Under eight boundary conditions resulting from particle displacement, stress, electric displacement, and potential continuity between the substrate's surface and reverse face, Equations (3) and (4) are determined for general solutions.

$$u_j = \alpha_j \exp(ikbx_3) \exp(ikx_1 - i\omega t) \quad (3)$$

$$\phi = \alpha_4 \exp(ikbx_3) \exp(ikx_1 - i\omega t) \quad (4)$$

Consequently, any change in the index ellipsoid of a crystal caused by a Lamb wave depends on Equations (5) and (6).

$$\Delta B_{ij} = \frac{1}{2} (p_{ijkl} S_{kl} + \gamma_{ijk} E_k + c.c.) \quad (5)$$

$$\Delta B_i = p_{IJ} S_J + \gamma_{Ik} E_k = p_{IJ} S_J - \gamma_{Ik} \phi_{,k} \quad (6)$$

3. Theory of Optical Mode Conversion by Lamb Waves

For optical mode conversion, the LiTaO₃ substrate shown in Fig. 1 was used. Amplitude and wave number vectors along the X_1 axis of polarized lights in X_2 and X_3 directions are assumed as follows:

$$(\phi_2(x_1), \beta_2), (\phi_3(x_1), \beta_3) \quad (7)$$

Then, the total field in the medium is expressed by the following equations.

$$\mathbf{E}_T = \phi_2(x_1)\mathbf{E}_2 + \phi_3(x_1)\mathbf{E}_3$$

$$\mathbf{H}_T = \phi_2(x_1)\mathbf{H}_2 + \phi_3(x_1)\mathbf{H}_3 \quad (8)$$

The anisotropy of the refractive index of the LiTaO₃ crystal provides different values for refractive index X_3 component n_{22} and refractive index X_2 component n_{33} . If we assume K as the wave number of an index cyclic field generated by the Lamb wave, the wave number matching condition is expressed by the following equation, and a theoretical Lamb wavelength can also be

determined.

$$\beta_{2^+} K = \beta_3 \quad (9)$$

$$K = \beta_3 - \beta_2 = \frac{2\pi n_{33}}{\lambda_0} - \frac{2\pi n_{22}}{\lambda_0} = \frac{2\pi(n_{33} - n_{22})}{\lambda_0} \quad (10)$$

$$\Lambda = \lambda_0 / (n_{33} - n_{22}) \quad (11)$$

If the above relation is used, the amplitudes of the polarized lights in the X_2 and X_3 directions are expressed by the following equations, respectively.⁶

$$\phi_2(x_1) = \cos(\alpha x_1), \quad \phi_3(x_1) = j\sqrt{C_{32}/C_{23}} \sin(\alpha x_1) \quad (13)$$

Here, C_{23} and C_{32} are coefficients of coupling.

$$C_{23} = C_{32}^* = [j \frac{1}{480\lambda_0} \int_H (E_{20}^* \Delta \epsilon_{23} \cdot E_{30}) dx_3] \quad (14)$$

$$\alpha = \sqrt{C_{23} C_{32}} \quad (15)$$

Let us assume P_{100} as the Lamb wave power required for 100% mode conversion. We then express P_{100} by the following equation.

$$P_{100} = \eta(D/L^2), \quad \eta = \pi^2 / (2\alpha)^2 \quad (16)$$

D : Width of the inter-digital transducer, L : Interaction length

4. Results of Calculation

The theoretical formula calculation result was obtained with a simulations. **Figure 2** shows the dependence of η on H when $A=132\mu\text{m}$ and $\lambda_0=0.63\mu\text{m}$. This result shows that η depends on thickness H .

5. Experiment

In this experiment, X-cut, Y-propagation and LiTaO₃ substrate were used. The experimental system is shown in **Fig. 3**. An analyzer is orthogonally positioned to a laser light incident on the polarized face in the X_3 direction. **Figure 4** shows the waveforms observed on an oscilloscope. The mode conversion light and Lamb wave are represented by ch1 and ch2, respectively. It was confirmed that the excitation of the Lamb wave induced the mode conversion. **Figure 5** shows conversion efficiency. It could be obtained up to 91%.

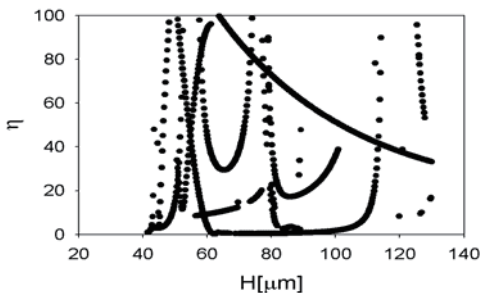

Fig.2 Dependence of η on H .

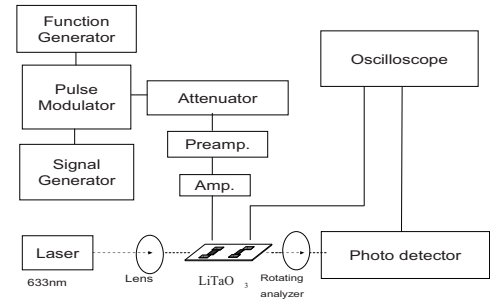

Fig.3. Experimental system for Optical mode conversion.

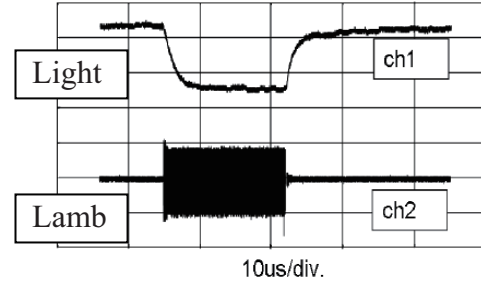

Fig.4 Measurement of mode conversion.

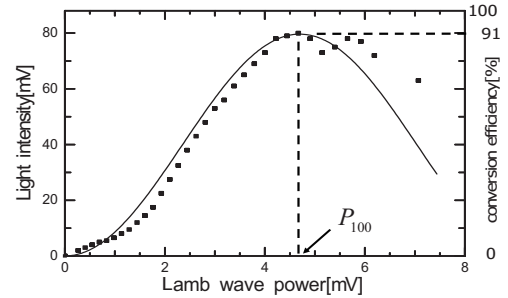

Fig.5 Conversion efficiency.

6. Conclusion

In this study, we examined the optical mode conversion by Lamb waves and proposed a high-efficiency optical mode converter on the basis of theoretical and experimental results. We will now determine the design guidelines for the acquisition of higher conversion efficiency in a theoretical and experimental technique.

References

1. H.F.Tiersten: J.Aoust. Soc.Am.59(1970)879.
2. M. Matsushita, H.Yao, K. Goohara, I. Hata and N. Kato : J.Phy. Soc, Jpn.54 (1985) 625.
3. Y. Nakagawa S.Tanaka and S. Kakio: Jpn.J.Appl.Phys., 42, (2003) 3086.
4. Y. Nakagawa M.Momose and S. Kakio: Jpn.J.Appl.Phys., 43, (2004). 3020.
5. Y. Nakagawa, M.Shigeda and S. Kakio: Jpn.J.Appl.Phys., 45, (2006)4667.
6. K.W. Loh, W. S.C. Chang, W.R. Smith, and T.Grudkowski: APPLIED OPTICS, vol.15,No.1(1976)156