

# Development of Noncontact Thickness Measurement Equipment for Steel Structure in Ports

## 港湾鋼構造物を対象とする非接触肉厚測定装置の開発

Natsuki Yoshizumi<sup>†</sup>, Sayuri Matsumoto, Taketsugu Hirabayashi, Muneo Yoshie, Tetsuya Shiraishi, Kageyoshi Katakura (PARI)  
吉住 夏輝, 松本 さゆり, 平林 丈嗣, 吉江 宗生, 白石 哲也, 片倉 景義 (港空研)

### 1. Introduction

Japan is a seafaring country. There are many steel structures such as steel sheet pile wall and steel pipe pier in ports. Steel structure is low cost compared with concrete structure. Thus, most of the structures were built during high economic growth. Recently, the aging structures become problem. An inspection technique that soundness of the structures can be diagnosed by easy measuring is desired.

Ultrasonic thickness gauging is one of the conventional inspection technique. Existing thickness of the object is measured by a diver in a port, and soundness is estimated. However, surface of the object is covered with a lot of shells. The diver must clean up them before the measurement. This cleaning process occupy 50 % of all working process.

To make the inspection more effective, the authors have developed noncontact ultrasonic measurement technique<sup>1-3)</sup> as a government-commissioned research. First, we made focused ultrasonic transducer as a noncontact probe. Second, to verify validity of the proposed method, we carried out experiment.

### 2. Noncontact Thickness Measurement

An image of proposed inspection technique is shown in Fig. 1. The diver holds ultrasonic transducer and moves along surface of the object. Fig. 2 is its profile. Aperture is 120 mm in diameter. Radiated ultrasonic pulse is focused at 400 mm distant from the transducer. Then, waveform like Fig. 3 will be measured. The waveform contains a transmitted ultrasonic pulse and a surface reflection and multiple reflections. Polarity of surface and multiple reflections are inverted. Interval of multiple reflections is constant. The interval corresponds to thickness of the object. If sound speed of the object is given, we will know thickness of the object. Advantage of the proposed technique is to be able to measure in continuity without cleaning up.

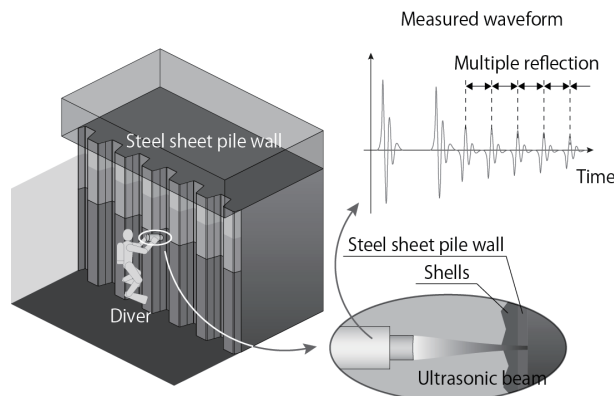

Fig. 1 An image of the proposed inspection technique for steel structures in ports.

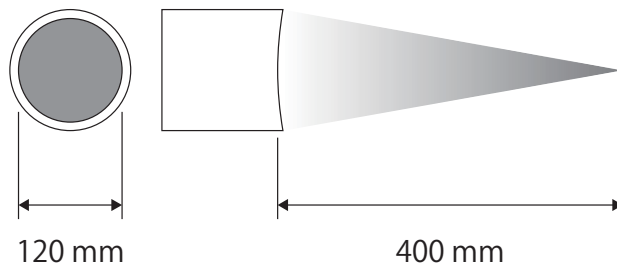

Fig. 2 A focused transducer for noncontact ultrasonic thickness measurement.

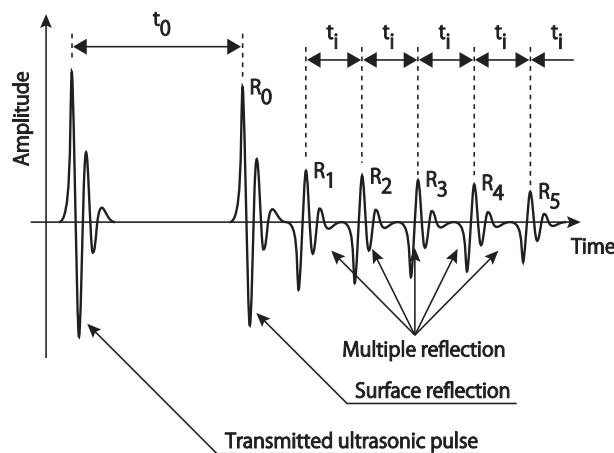

Fig. 3 An image of measured waveform.

yoshizumi@pari.go.jp

### 3. Scanning Measurement

Noncontact thickness measuring experiment was carried out by scanning measurement. The experimental setup is shown in Fig. 4. Object is a steel plate 18.6 mm thick with a channel whose depth and width are 1.6 mm and 25 mm, respectively. The thinnest thickness is 17 mm. Transducer is linearly scanned in a direction perpendicular to the channel. Distance between the transducer and object is 400 mm. The transducer is driven by one cycle of sinusoidal wave. Frequency is 1 MHz and applied voltage is 20 V. Ultrasonic wave is radiated from aperture 120 mm in diameter and focused on the surface of the object. Most part of the wave is reflected by the surface. Remaining part goes into the inside, and multiple reflections are generated.

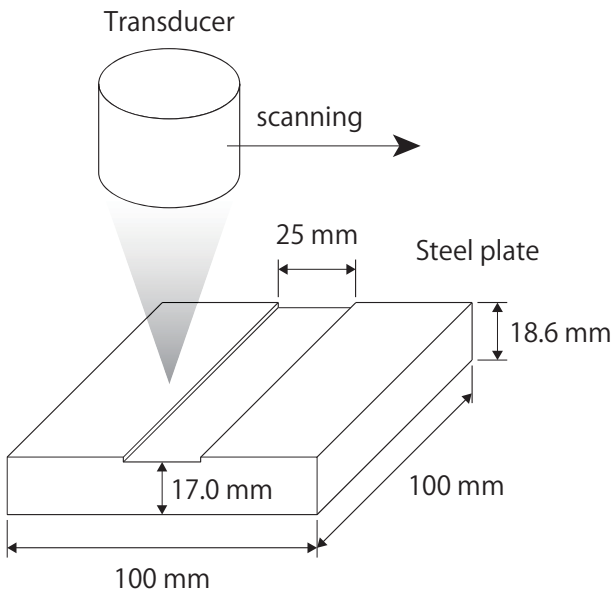

Fig. 4 Experimental setup for noncontact thickness measurement of steel plate with a channel.

Cross-sectional image is visualized by 1 MHz frequency component. Result of imaging is shown in Fig. 5. This is a B-mode image gray scale indicates amplitude of the data. The profile of the object with the channel was visualized, and multiple reflections are appeared as ringing response in the image.

Thicknesses were estimated by intervals of multiple reflections. Fig. 6 shows results. Thickness distribution of the object was measured with up to +0.2 mm errors. The result shows that noncontact scanning measurement is usable method.

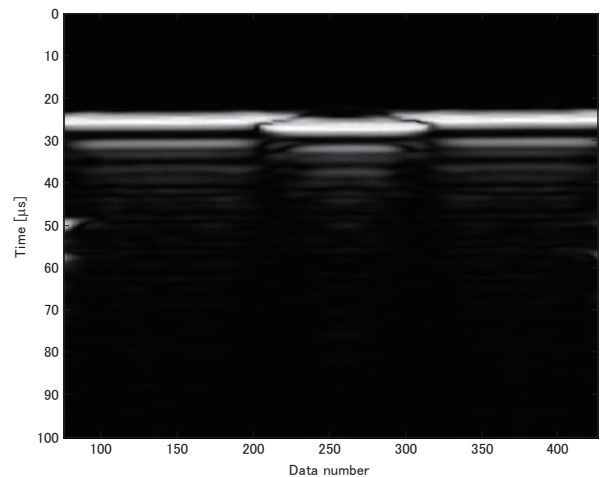

Fig. 5 Imaging result (B-mode image).

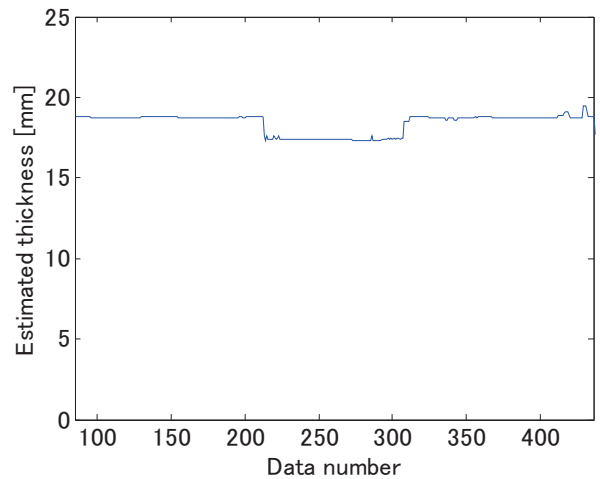

Fig. 6 Estimated thicknesses.

### 4. Conclusion

We developed noncontact ultrasonic thickness measurement technique. We focused on ultrasonic multiple reflection, and it made noncontact measurement possible. To validity of the proposed technique, experiment was performed. As a result, we confirm that the proposed technique has enough ability for scanning measurement.

### References

1. N. Yoshizumi, S. Matsumoto, K. Katakura, T. Matsumoto, H. Fukuda, H. Kume, Proc. of USE2009, pp.173-174 (2009)
2. N. Yoshizumi, S. Matsumoto, K. Katakura, T. Matsumoto, H. Fukuda, H. Kume, IEICE Tech. Rep. US-2009-37, pp.43-48 (2009) [in Japanese]
3. N. Yoshizumi, S. Matsumoto, K. Katakura, H. Hashimoto, N. Tomoda, K. Ishinuki, IEICE Tech. Rep. US-2008-62, pp.7-12 (2008) [in Japanese]