

Laser ultrasound technique for the determination of temperature profiles in layered medium.

Sheng-Po Tseng¹, Che-Hua Yang²

(Institute of Manufacturing Technology, National Taipei University of Technology)

Abstract

This research is focused on the dispersion curve of steel plate with different temperature gradient by laser ultrasonic technique (LUT). With the LUT, the acoustic waves propagating in different temperature gradient are generated and detected by optical means. The phase velocity will change when the samples heated and have the temperature gradient. By measuring the dispersion spectra, the relation between dispersion curve and temperature gradient are established. This technique is being developed towards an inspection for LED internal temperature distribution.

Keywords : laser ultrasound technique , temperature gradient , dispersion curve.

1. Introduction

For the LED, the internal temperature is very important that it will affect not only the luminous efficiency but also the product lifetime. [1] Because of the package and finite size, the internal temperature of LED is difficult to measure ideally with traditional technique such as thermocouple technique or infrared radiation technique. The thermocouple technique has good accuracy but it must be installed within the product before package. The infrared radiation technique can provide non-contact measurement but only can measure the temperature on the surface. [2~4]

This research is focused on developing a non-contact, non-destructive and high accuracy measurement technique based on LUT. [5][6]

2. Experimental setup

Fig. 1 shows the experimental configuration consisting of a pulsed laser for the generation of ultrasonic waves and a laser-based optical detector for the detection of acoustic waves. A B-scan scheme is used for the measurement of the dispersion behaviors. During scanning, the optical detector is located at a fixed point, while the generation laser beam is scanned along the samples. A two-dimensional fast Fourier transform (2D-FFT), first taken with respect to time and then with respect to the scanned position, is used to obtain the dispersion relation from the B-scan data.

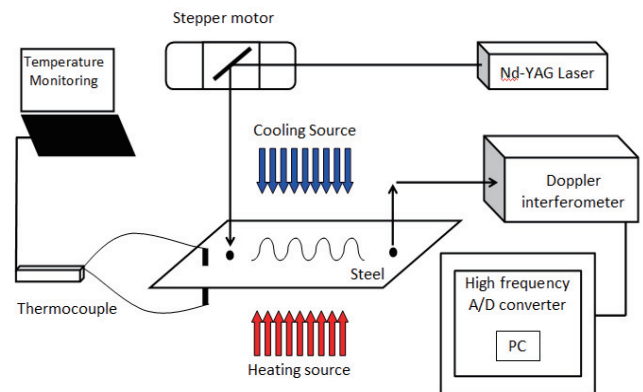

Fig. 1 Experimental configuration

The investigated samples are steel plates with thickness 0.05mm. To obtain the temperature gradient in the samples, a heating plate is set at one side of samples and a cooling source is in the other side. Thermocouples attached on the surface are used to measure the temperature on the top and bottom surface respectively.

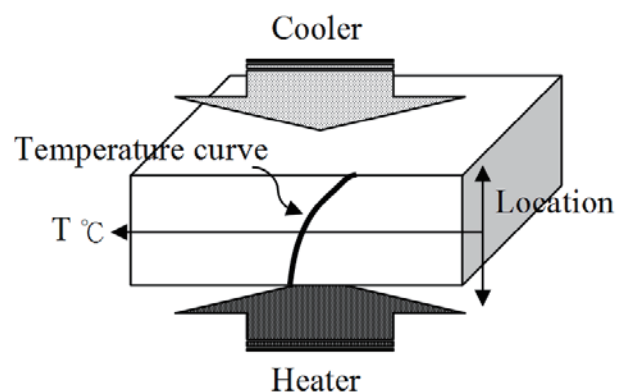

Fig. 2 A schematic showing temperature distribution on the sample.

3. Results and Discussions

Fig.3 shows the steel plate dispersion curves with uniform and gradient temperature distribution measured by LUT. In Fig.3, triangle symbol is the

dispersion curve for the steel plate with uniform temperature at 190°C; circular symbol is the steel plate with gradient distribution from 72°C to 190°C. In this figure, significant curve difference in higher order modes can be observed.

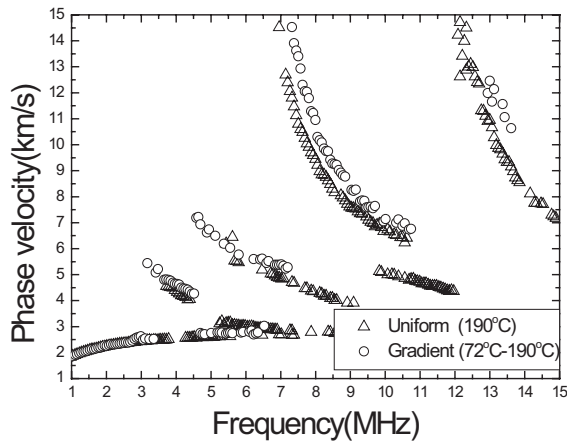

Fig. 3 Dispersion curve for different temperature distribution.

Fig. 4 shows the steel plate dispersion curve with different cooling source. The triangle symbol indicates measurement results for the temperature gradient from 84°C to 220°C and the square is from 91°C to 220°C. In Fig. 4, it is found out that the steel plate with lower cooling source will have higher phase velocity in the same frequency. Also, the higher order modes can have better sensitivity on temperature difference.

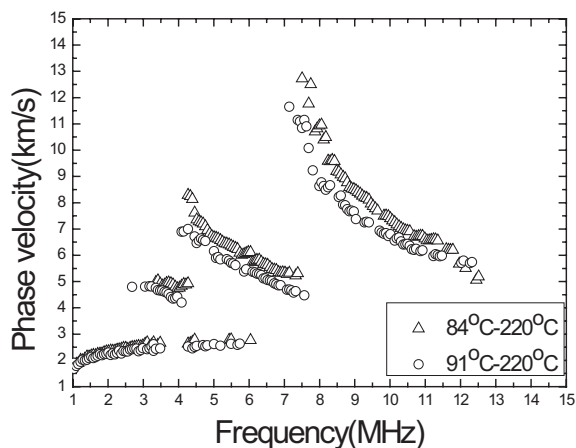

Fig. 4 Dispersion curve for different cooling source.

4. Conclusions

This paper demonstrates a procedure employing a LUT introduced the dispersion curves for the steel plate with different temperature distribution. In the spectra, the higher mode dispersion curve could be observed more significant

phase velocity difference by LUT system. The phenomenon of temperature gradient is more sensitive with the higher mode. According to the sensitivity, the better resolution on temperature difference can be applied on the tiny temperature variation. Currently this technique is being developed towards an inspection for LED internal temperature distribution.

References

1. Z.Z.Chen and P.Liu . etc : Materials Science in Semiconductor Processing , 10(2007), pp. 206-210.
2. N. Kashiwagura, M. Akita, and H. Kamioka: Jpn. J. Appl. Phys. 44(2005) 4339.
3. M. Takahashi and I. Ihara: Jpn. J. Appl. Phys. 47 (2008) 3894.
4. M. Takahashi and I. Ihara: Jpn. J. Appl. Phys.48(2009) 07GB04
5. R. M. White : Journal of Applied Physics, vol. 34, no. 12, 1963, pp. 3559-3567
6. Che-Hua Yang , Kun-Yi Tsai : Ultrasonics 44 (2006) e807–e811