

Underwater acoustic channel estimation for OFDM system

Chundan Lin¹, Wansong Zhang¹, Jong Rak Yoon², Zhenqing Yang¹ and Kyu-Chil Park^{2*} (¹College of Science, China Univ. of Petroleum, Beijing, China; ² Dept. of Information and Communications Eng., Pukyong National Univ., Busan, Korea)

1. Introduction

Orthogonal frequency division multiplexing (OFDM) has applied into underwater acoustic (UWA) communication due to the fact that OFDM is robust to against frequency selective fading effects. For OFDM system channel estimation is required for signal demodulation. In addition, OFDM is very sensitive to carrier frequency offset which distorts the orthogonality between subcarriers resultig in intercarrier interference (ICI). The advangate of ICI self cancellation sheme is very simple to implement the task of reducing ICI effects. In this paper windowed DFT based channel estimation combined with ICI self-cancellation scheme is proposed to combat against frequency offset and achieve high data rate transmission.

2. Communication system

A pilot-assisted OFDM system is shown in Fig.1. The data will be mapped as a complex signal according to quadrature phase shift keying (QPSK) modulation. N is the total number of subcarriers and T is OFDM symbol duration. The signal after modulated by carrier frequency can be represented as

$$x(t) = \mathbf{exp}(j2\pi f_c t) \sum_{k=0}^{N-1} b_k p(t - \frac{kT}{N}) \quad (1)$$

where f_c is the carrier frequency and $p(t)$ is the impulse response of the low-pass filter of the transmitter.

Considering frequency offset Δf , after sampling, the demodulated signal can be written as

$$y_k = b_k \mathbf{exp}\left(\frac{j 2 \pi k \Delta f T}{N}\right) \quad (2)$$

The received signal on subcarrier m after FFT process is given by

$$c_{n-m} = \frac{1}{N} \frac{\mathbf{sin}(n-m+\Delta f T)}{\mathbf{sin}\pi\left(\frac{n-m+\Delta f T}{N}\right)} \times \mathbf{exp} j\pi \frac{(N-1)(n-m+\Delta f T)}{N} \quad (3)$$

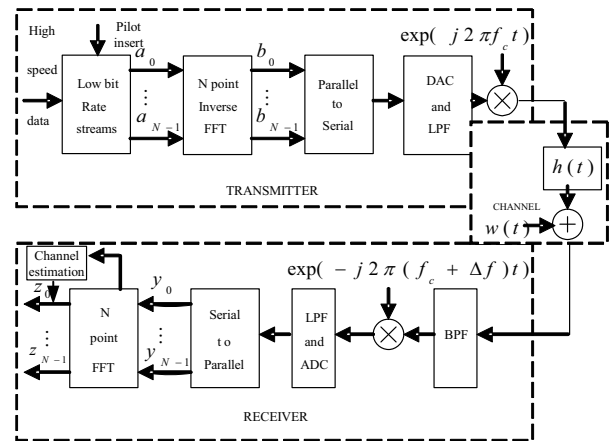

Fig.1 Pilot-assisted OFDM system model

To cancel ICI, in this scheme the input data are required to meet

$$a_0 = -a_1, a_2 = -a_3, \dots, a_{N-2} = -a_{N-1} \quad (4)$$

Then the decoded value at the zeroth carrier is given as

$$z_0 = (c_0 - c_1)a_0 + \dots + (c_{N-2} - c_{N-1})a_{N-2} \quad (5)$$

Finally the data can be obtained by subtracting values $z_0 \dots z_{N-1}$ in pairs

$$z_0 - z_1 = (-c_{-1} + 2c_0 - c_1)a_0 + (-c_1 + 2c_2 - c_3)a_2 \dots (-c_{N-3} + 2c_{N-2} - c_{N-1})a_{N-2} \quad (6)$$

maximize the overall signal to noise ratio (SNR). This is ICI self-cancellation scheme.

To estimate the mutipath channel, M nonzero pilot subcarriers are inserted into the N subcarriers as follows:

$$\gamma_m = a_M \quad m = -M/2, \dots, M/2 - 1 \quad (7)$$

where γ_m are pilot signals which are known to the receiver. The least squares (LS) estimates of the channel frequency response can be obtained at the pilot subcarrier frequencies

$$H_M = \frac{z_M}{\gamma_m} \quad (8)$$

Email: jryoon@pknu.ac.kr

In order to reduce the spectral leakage and bring the data smoothly to zero at the boundaries, two window function is applied:

$$d_{rec}(m) = \begin{cases} 1, & m = -M/2, \dots, M/2-1 \\ 0, & \text{otherwise} \end{cases} \quad (9)$$

$$d_{ham}(m) = \begin{cases} 0.54 + 0.46 \cos(2\pi m / M), & m = -M/2, \dots, M/2-1 \\ 0, & \text{otherwise} \end{cases} \quad (10)$$

$$H_p = H_M d(m) \quad (11)$$

Then an M -point IFFT can be performed to transform the windowed frequency response into the time domain as follows

$$h'(i) = \frac{1}{M} \sum_{m=-M/2}^{M/2-1} H_p \exp(j \frac{2\pi}{M} mi), \quad (12)$$

$$i = 0, \dots, M-1$$

Next, zeros are inserted into the middle of $\{h'\}$ to get a N point sequence as

$$h_N(i) = \begin{cases} h'(i), & 0 \leq m \leq -M/2 \\ 0, & \text{otherwise} \\ h'(i), & N - M/2 + 1 \leq m < N \end{cases} \quad (13)$$

After N -point FFT process, adding zeros in time domain is equivalent to doing the interpolation in the frequency domain. Finally windowing will be removed and the estimated channel frequency response can be obtained by windowed DFT based estimators.

3. Simulation results

To evaluate the proposed scheme, simulations for an OFDM system with $N = 1024$ are performed under a multipath channel whose discrete channel transfer functions $H(z)$ is given by

$$H(z) = 1 + 0.39z^{-8} - 0.40z^{-13} - 0.27z^{-21} \quad (14)$$

The system performance is evaluated based on the symbol error rate (SER) and estimator mean square errors (MSE) of the channel response in frequency domain. Rectangle window corresponds to the direct DFT based channel estimation method. In this paper, direct DFT based estimation, Hamming windowed DFT based estimation and Hamming windowed DFT based estimation with ICI-self cancellation method are compared. Fig. 2 illustrates the MSE of the estimated frequency response for the normalized carrier frequency offset

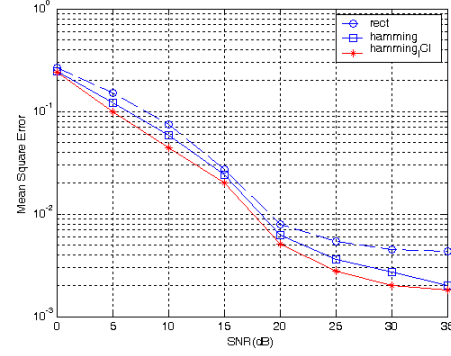

Fig. 2 Estimator MSE performance

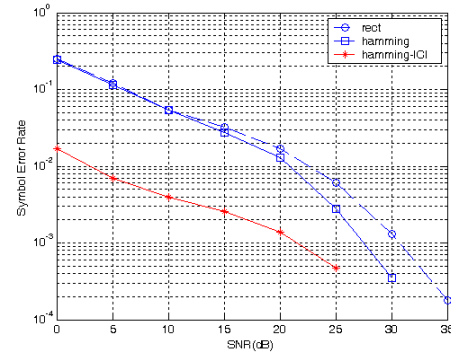

Fig.3 SER performance

$\Delta f T = 0.04$. Hamming windowed DFT systems don't have a big difference at low values of SNR compared with direct DFT system. From Fig.3 it can be seen that the system SER is also not sensitive to the channel estimation errors at low SNR. At high SNR, hamming windowed DFT systems with ICI cancellation and without ICI cancellation both have much better performance than the direct DFT system. Due to the advantage of ICI-self cancellation scheme, i.e., removing ICI completely, Hammig windowed DFT with ICI self cancellation outperforms among the three systems.

4. Conclusion

Simulation results demonstrate that OFDM system employing Hamming windowed DFT based estimation with ICI self-cancellation can improve system performance, effectively suppress ICI effects and achieve good performance in time-varying UWA channel with low-complexity.

Acknowledgment

This work was supported by the Pukyong National University Research Fund in 2010(PS-2010-04100)

References

1. J. Armstrong: IEEE Trans. On Comm. **47** (1999) 365.
2. B. Yang, Z. Cao and K. B. Letaief: IEEE Trans. On Comm. **49** (2001)1977.
3. J. Wen : Computer Comm. **31** (2008) 2124