

Change of Ultrasonic Wave Properties during Soil Freezing

Jung-Hee Park^{1†}, Seung-Seo Hong², Young-Seok Kim², Jong-Sub Lee¹ (¹Korea Univ., ²Korea Institute of Construction Technology)

1. Introduction

A freezing phenomenon of soils affects on the soil properties and causes the significant damage to the geo-structures such as pavements, railroads and foundations. Several experimental studies have been performed for the characterization of the frozen soils and for the prevention of the geo-structures. One of the experimental studies used the ultrasonic waves including compressional and shear waves in liquid. Thus, frozen soils are submerged into kerosene. The shear waves in liquid can be measured through the mode conversion. This traditional ultrasonic wave method, however, may characterize the properties of the completely frozen soils. Thus, new ultrasonic wave method has been required to characterize soil properties during soil freezing. In this study, ultrasonic wave properties are continuously monitored when the temperature changes from 20°C to -10°C. Experiments were carried out using a nylon cell designed to freeze specimen from top to bottom and to equip the shear wave transducers. The specimen, which is prepared by mixing sand and silt, is frozen in the refrigerator. In this study, three properties of shear waves including shear wave velocities, amplitudes and frequencies are continuously measured during temperature change. This paper consists of a experimental setup, measurements, analyses and conclusion.

2. Experimental Setup

Specimens were prepared by using sand and silt. Jumunjin 30/50 sand. The diameter of the sand particles ranges from 0.3mm to 0.6mm. The physical properties of the sand are summarized in **Table I**.

Table I. Physical properties of sand

Property	G _s	D ₅₀	e _{max}	e _{min}
Sand	2.62	0.45	0.82	0.56

The specimen was prepared by mixing the sand and silt. The relative density of sand before mixed with silt is 70%. The weight fraction of silt (% of silt = $W_{silt}/W_{sand} \times 100\%$) is 10% and water fraction (% of water = $W_{water}/W_{sand} \times 100\%$) is 10%. The specimen was placed into the freezing cell in four layers and was compacted by applying the same tamping energy to each layer.

A nylon cell for freezing specimen is represented in Fig. 1. The cell consists of four pieces of the nylon plates to remove the vibration propagating through nylon cell. Bender elements are used as the ultrasonic shear wave transducers (Lee and Santamarina)¹. Three pairs of the bender elements for the transillumination (Lee and Santamarina)² of ultrasonic shear waves are attached on the side walls on the three location along the depth: top (A), middle (B) and bottom (C) as shown in Figure 1(a). The cell is fixed in refrigerator. The temperature inside refrigerator was maintained at the temperature of -50 °C.

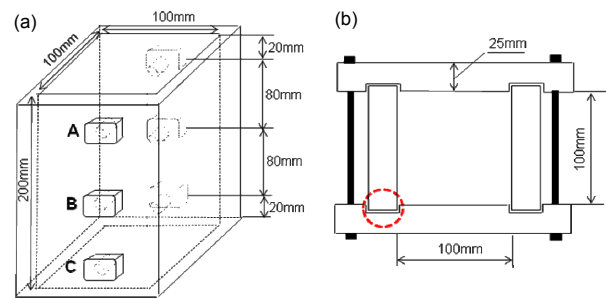

Fig. 1. Freezing cell (a) 3D image ; (b) Top view.

The ultrasonic shear wave measurement system is shown in **Fig. 2**. Input signals are generated by a signal generator. Filtered signals are captured by oscilloscope and saved by a computer. Ultrasonic shear waves are continuously measured while the temperature of the specimen drops from 20°C to -10°C at three different locations along the depth.

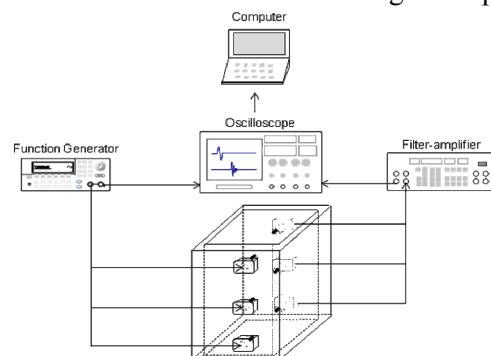

Fig. 2. Measurement system of shear waves

3. Results and Analyses

The ultrasonic shear waves measured from 20°C to -10°C at the top, middle and bottom of the freezing cell and ultrasonic shear wave velocity

jongsub@korea.ac.kr

versus temperature are plotted in **Fig. 3**. Fig 3 shows that the first arrival of the ultrasonic shear waves decreases with the decrease in the temperature. The first arrival dramatically decreases and the wave signature changes dramatically at the temperature of around 0°C at the three locations of the freezing cell. The shear wave velocity, which is the ratio of the tip-to-tip distance of the bender elements to the first arrival, increases as the depth of specimen increases at the temperature of 20°C~2°C. However, the ultrasonic shear wave velocities at three different locations dramatically increase at the temperature of 0°C. The shear wave velocities at the top and middle of specimen are almost identical at the -10°C. The shear wave velocity at the bottom of specimen is greater than that at the top and bottom at the -10°C. The huge change of the shear wave velocity demonstrates that the dominant factors, which affect on the ultrasonic shear wave velocities, change from the overburden stress to the ice bonding.

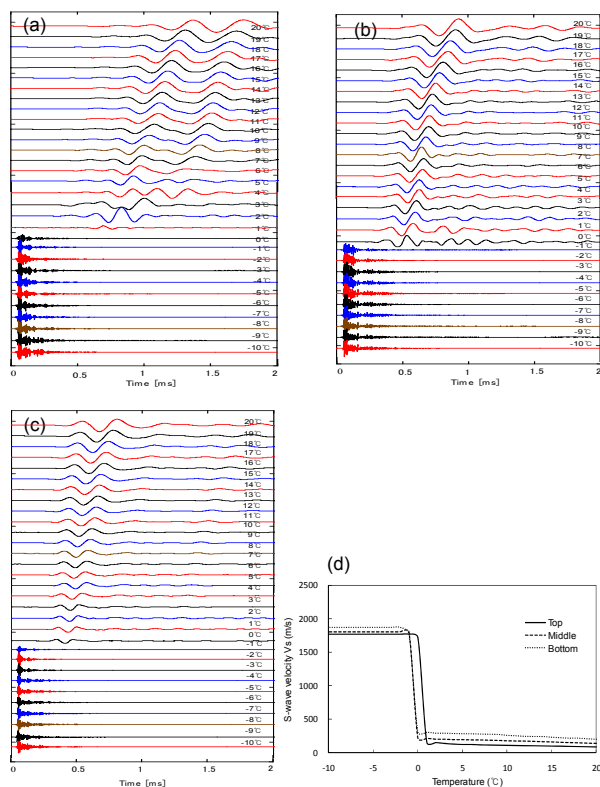

Fig. 3. Freezing results: (a) Shear waves at top; (b) Shear waves at middle; (c) Shear waves at bottom (d) Shear wave velocity versus temperature

Fig 3 illustrates not only the change of ultrasonic shear wave velocities but also the change of amplitudes along the temperature change. The amplitudes of shear waves decrease when the temperature changes from 2°C to 0°C. The amplitudes, however, increase when the temperature is lower than 0°C. The amplitude

change of the transmitted ultrasonic shear waves results from the phase change within the specimen. The change of the phase alters the impedance of the specimen. The impedance change within the specimen decrease the amplitude of the ultrasonic shear waves.

Resonant frequencies versus temperatures are presented in **Fig. 4**, which shows that the greatest frequency is measured at the temperature of 0°C. In addition, the phase change of water between the particles from liquid to solid bridge has a huge influence on the resonant frequency of ultrasonic shear wave. The changes of the resonant frequency due to the temperature change at three locations are similar with the changes of ultrasonic shear wave velocities.

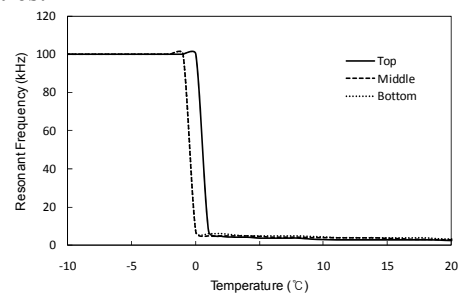

Fig. 4. Resonant frequency vs. Temperature

4. Conclusions

This study is to investigate the change of ultrasonic shear wave properties in soils due to the temperature change. The ultrasonic shear waves are continuously measured as the temperature of soils changes from 20°C to -10°C. Experimental result shows that the velocities and resonant frequencies of the ultrasonic shear waves dramatically increase and the amplitudes of ultrasonic shear waves decrease rapidly at the temperature of 0°C. This study demonstrates that the dominants factors, which affects on the ultrasonic shear wave, change from the overburden stress to the ice bonding.

Acknowledgment

The “Development of the platform technology for quick construction of the substructure at the polar region”, which is the key development project of the Korea Institute of Construction Technology for 2011 provided the assistance to this study.

References

1. J. S. Lee, and J. C. Santamarina: J. Geotech. Geoenviron. Eng., **131**(2005).
2. J. S. Lee, and J. C. Santamarina: Canadian Geotech. Journal., **44**(2007).