

Construction of Two-Axis Acceleration Sensor Using a Cross-Coupled Vibrator

交差結合型振動子を用いた2軸加速度センサの構成

Jiro Terada¹⁺, Yasutomo Uetsuji¹, Sumio Sugawara² (¹Faculty of Eng., Osaka Inst. of Tech.; ²Faculty of Sci. and Tech., Ishinomaki Senshu Univ.)

寺田 二郎¹⁺, 上辻 靖智¹, 菅原 澄夫² (¹大阪工業大 工; ²石巻専修大 理工)

1. Introduction

Recently, a small low-cost acceleration sensor with high sensitivity has been required for application to the attitude control and navigation systems of moving objects, such as vehicles. To develop such a sensor, the authors have studied an acceleration sensor utilizes the phenomenon that the resonance frequency of a bending vibrator changes by the axial force.¹⁻¹²⁾

A new construction of the acceleration sensor using a cross-coupled vibrator is proposed here, and investigated experimentally. The sensor detects the acceleration from a change of vibration amplitude of the cross coupled vibrator.

2. Structure of Sensor

Fig. 1 shows the structure of the two axis acceleration sensor using a cross-coupled vibrator. The two coupled vibrators¹²⁾ are mechanically cross-coupled as shown in the figure. The cross-coupled vibrator is fixed to the frame at four ends, and the center portion of the vibrator is connected to mass at four points with a cross-coupled bar. Also the mass is fixed to the frame with movable gimbal mechanism. This sensor structure detects the two accelerations along the x-and y-axes.

The vibration mode of the coupled vibrator is shown in Fig. 2(b). Fig. 2(a) shows the vibration mode of the bending vibrator³⁾, the displacements at

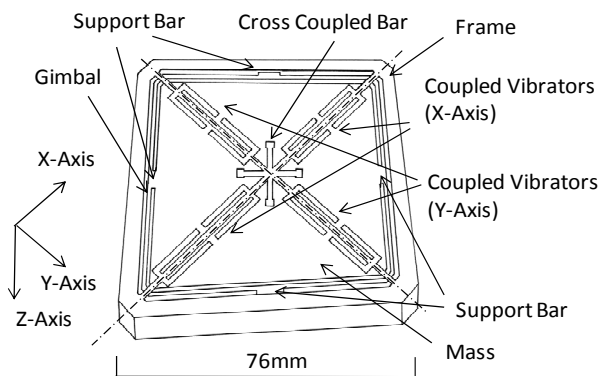
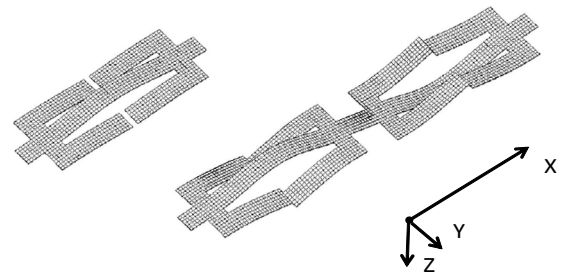

Fig. 1 Structure of sensor.

the both ends are designed so as to become very small.²⁾ The vibration mode of the y-axis is the same as x-axis. The experimental sample of the sensor is made from stainless steel (SUS304). The volume of the experimental sample is about 76×76×8 mm³. The thickness of a cross-coupled vibrator is 0.2 mm.



(a) Bending vibrator (b) Coupled vibrator
Fig. 2 Vibration modes of vibrator(X-Axis).

3. Driving and detecting methods of Sensor

Fig 3(a) shows a cross section of the sensor. Four small piezoelectric ceramics (2×8×0.1 mm³)

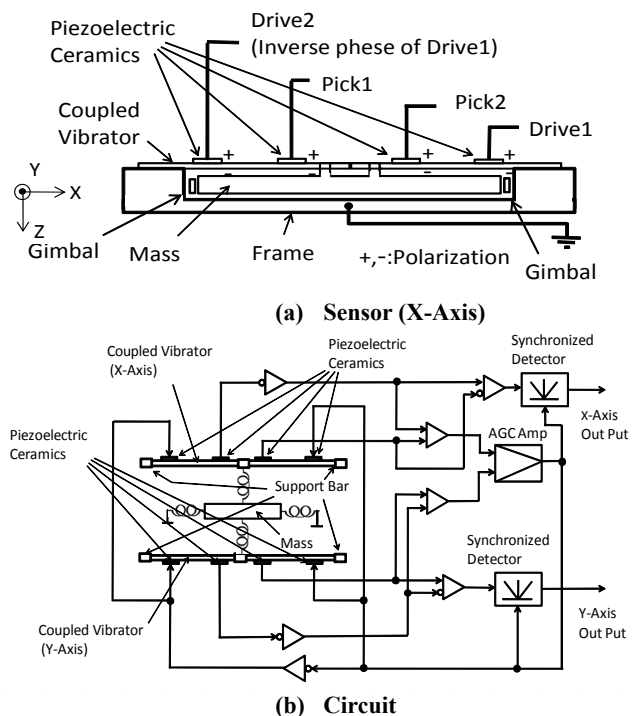

(a) Sensor (X-Axis) (b) Circuit
Fig. 3 Driving and detecting methods of sensor.

Mail address: teramat@rsh.oit.ac.jp

are bonded on the long arms of the coupled vibrator, and electrically connected for driving and detecting the vibrator as shown in Fig. 3(b). The vibrator is driven with the constant amplitude using an AGC amplifier, and the output signals are detected differentially. The sensor output is obtained using a synchronized detector.

4. Sensor Characteristics

The experimental sample of the sensor is shown in Fig. 4. The measured values of resonance frequency and quality factor are about 1041Hz and 87, respectively. The sensor characteristics are measured using the gravitational field, and the acceleration is changed by rotating the sensor around the axis along the length of the vibrator. The measured characteristics are shown in Fig. 5. The drive voltage is 1V rms then. When the acceleration along the x-axis is applied to the sensor relationship between the acceleration value and the output voltage V_{out} becomes linear as shown in Fig. 5(a). Here, V_{out} shows the differential voltage between V_{pick1} and V_{pick2} , which are the output voltages at the terminals Pick1 and Pick2 in Fig. 3(a). Fig. 5(b) shows the characteristic in the case of the acceleration applied along the y-axis.

The sensitivity of 13mV/m/s² and the linearity of 0.86% were realized experimentally.

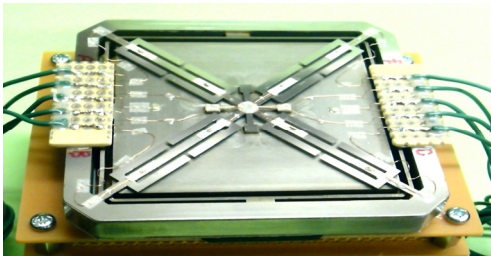

Fig. 4 Experimental sample of sensor.

5. Conclusions

A new construction of the two-axis acceleration sensor using a cross-coupled bending vibrator was proposed, and the sensor characteristics were measured experimentally. The obtained results are summarized as follows.

- (1) The acceleration sensor can be realized using the change in the vibration amplitude of the vibrator.
- (2) The sensitivity of 13mV/m/s² is realized using the large experimental sample of the sensor.
- (3) The linearity of 0.86% is also realized using the differential detection of the coupled vibrator. Based on these results, the MEMS sensor was constructed from a silicon single-crystal and

piezoelectric thin films, and designed by the finite-element method so as to have the volume of 4×4×0.5 mm³. The following result was also obtained.

- (4) The sensitivity of 15mV/m/s² can be realized.

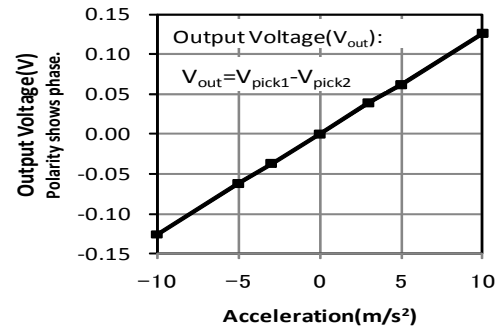

(a) X-Axis

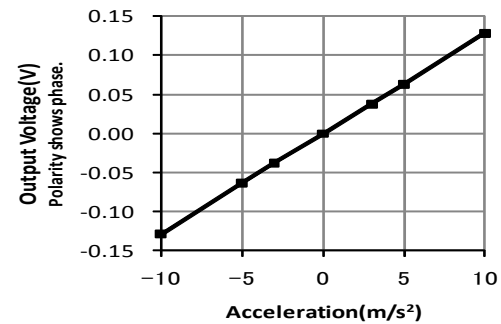

(b) Y-Axis

Fig. 5 Measured characteristic of acceleration—output voltage.

References

- 1) S. Sugawara, K. Masuda, and Y. Tomikawa: Jpn J. Appl. Phys., **40** (2001) 3683.
- 2) S. Sugawara, J. Takahashi, and Y. Tomikawa: Jpn J. Appl. Phys., **41** (2002) 3433.
- 3) J. Takahashi, S. Sugawara, and J. Terada: Jpn J. Appl. Phys., **42** (2003) 3124.
- 4) J. Takahashi, and S. Sugawara: Jpn J. Appl. Phys., **43** (2004) 3035.
- 5) S. Sugawara and J. Terada: Proc. 25th Symp. Ultrasonic Electronics, 2004, 185 [in Japanese].
- 6) S. Sugawara and J. Terada: Choonpa Tekuno, 18 (2006) No. 1, 20 [in Japanese].
- 7) S. Sugawara, H. Suzuki and T. Saito: Jpn J. Appl. Phys., **46** (2007) 4652.
- 8) S. Sugawara, T. Watanabe, and J. Terada: Jpn J. Appl. Phys., **47** (2008) 4048.
- 9) S. Sugawara, and J. Koike: Jpn J. Appl. Phys., **47** (2008) 6578.
- 10) S. Sugawara, M. Yamakawa, and S. Kudo: Jpn J. Appl. Phys., **48** (2009) 07GF04-1.
- 11) S. Sugawara, and Y. Kajiwara: Jpn J. Appl. Phys., **49** (2010) 07HD02-1.
- 12) J. Terada, S. Sugawara, and Y. Mito: Jpn J. Appl. Phys., **50** (2011) 07HC04-1.