

## Pipe Inspection Based on Mode Conversion of Torsional Waves Generated by EMAT

Nurmalia<sup>1‡</sup>, Nobutomo Nakamura<sup>1</sup>, Hirotsugu Ogi<sup>1</sup>, Masahiko Hirao<sup>1</sup> (<sup>1</sup>Grad. School of Eng. Sci., Osaka Univ.)

### 1. Introduction

Torsional guided wave shows great potential for nondestructive testing (NDT) of cylindrical waveguides for several reasons. It is relatively less attenuated and provides the capability to inspect a longer specimen in a single measurement. Because the particle displacement is parallel to the specimen's surface, this wave mode is less affected by coatings and liquid loadings. This mode of wave also has much simpler dispersive characteristics compared with other guided waves, resulting in easier interpretation.

In the present study, an NDT method based on group velocity change of torsional waves caused by mode conversion is proposed for wall-thinning inspection of metal pipes. Every higher mode has a critical thickness, so-called the "cut-off thickness", for a given driving frequency, below which the mode cannot exist and it is expected to convert into lower modes. This nature provides the basis for wall-thinning inspection by velocity measurement. This method has been successfully implemented for the case of shear horizontal (SH) waves propagating in a plate.<sup>1,2</sup>

Group velocity measurement is less susceptible to several factors affecting the amplitude-based measurement hence it is more reliable. The electromagnetic acoustic transducer (EMAT) is used to generate the intended torsional waves here.<sup>3</sup> This provides additional benefits from the noncontact nature of EMAT. It eliminates the inherent drawbacks caused by a couplant used with contact piezoelectric transducers.

In this study, the mechanism of mode conversions for the fundamental T(0,1) and first higher T(0,2) modes is specifically described. This is a continuation of the previous observations on mode conversion.<sup>4</sup> In that experiment, T(0,1) and T(0,2) modes were generated and propagated in several aluminum pipes containing circumferential thinned regions at the center. Two EMATs for generating and receiving torsional waves were placed in both sides of the thinning region and

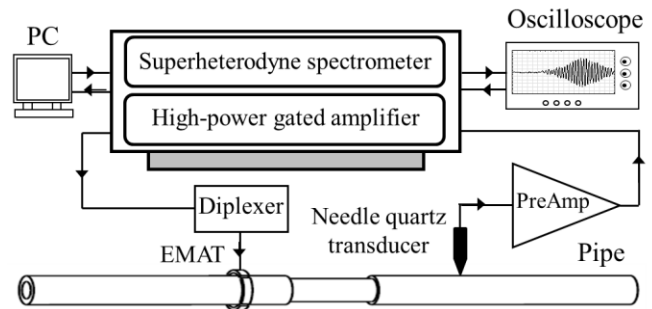

Fig. 1 Experimental setup

separated by a given distance. The traveling time was then measured referring to the specific phase of received signal. When the T(0,2) mode was generated, it was found that the traveling time significantly dropped in every specimen where the remaining thickness in the thinning region was smaller than the cut-off thickness. This result indicates a mode conversion from T(0,2) into T(0,1) mode with a higher group velocity in the thinning region. Based on this finding, additional experimentation was conducted to understand the mechanism of mode conversion and the results are reported here.

### 2. Experimental Setup

A straight pipe of 1000-mm long, inner and outer diameters of 19 and 25 mm, respectively, was used as the specimen. The material was aluminum alloy A5052. It contained a 200-mm long circumferential reduction in outside diameter located at the center (**Fig. 1**). In this region, the remaining thickness was 1 mm. The fundamental T(0,1) and first higher T(0,2) modes were generated by a periodic permanent magnet (PPM) EMAT and detected by a home-made needle-type quartz transducer. This transducer, which is manually moved along the pipe, can detect various modes caused by mode conversion.

The high-power tone bursts drive the generating EMAT with a specific frequency to excite the corresponding torsional mode in the pipe. The propagating mode is picked up by the

-----  
nurmalia@abc.me.es.osaka-u.ac.jp

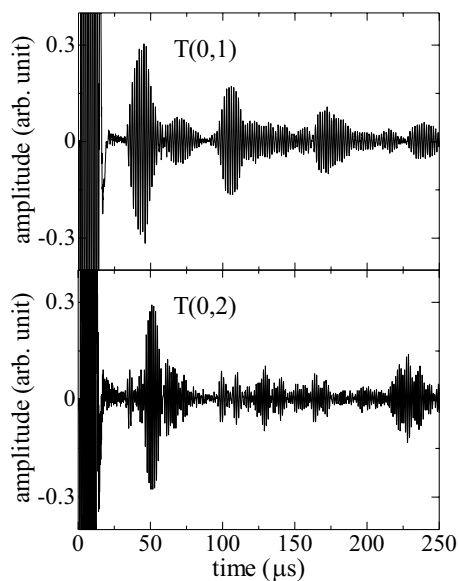

Fig. 2 Typical waveforms for T(0,1) and T(0,2) modes.

transducer, the waveform is recorded, and the signal is sent to a superheterodyne spectrometer for signal processing after being pre-amplified. The receiving transducer was moved every 5 mm along the pipe.

### 3. Results and Discussion

The T(0,1) and T(0,2) modes were generated with the driving frequencies of 0.615 MHz and 0.77 MHz, respectively. **Figure 2** shows their typical waveforms, where the intended signal is the first arriving wave. **Figure 3** compiles the waveforms received at all points when T(0,1) or T(0,2) mode is generated. For each mode, the waveforms are sorted from top to bottom by the distance from the EMAT. Then the slope corresponds to the group velocity. The thinning region is located at the interval of 200-400 mm, indicated with the rectangle. The signal appearing around  $t=0$  is the noise by the driving signals of EMAT. Each intended signal was gated and its traveling time was determined from the phase shift by means of a PC program. The group velocity was then determined by this measured traveling time of every point with a known distance.

The T(0,1) mode propagates with a constant group velocity before and through the thinning region. Reflection at the edge of the thinning region is also observed. The measured group velocities are 3.17 and 3.11 mm/μs, before and in the thinning region, respectively. However, the group velocity drops to 1.8 mm/μs after the thinning region as is also shown by the slope change in Fig. 3(a). This group velocity change indicates mode conversion from T(0,1) mode to the higher T(0,2) mode.

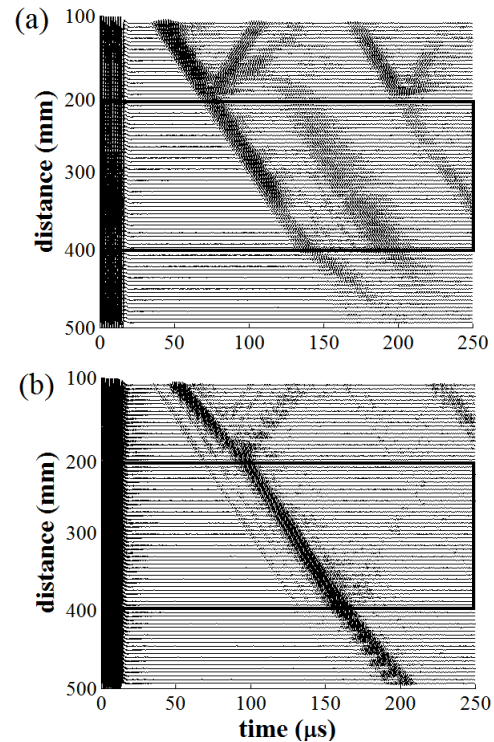

Fig. 3 Received waveforms at all the measuring points for the T(0,1) and T(0,2) modes are shown in (a) and (b), respectively.

For the T(0,2) mode, Fig. 3(b) shows a slope change in the thinning region. The measured group velocities are 2.06, 3.11 and 2.49 mm/μs, before, through, and after the thinning region, respectively. This result indicates conversion from the T(0,2) mode to the lower T(0,1) mode with a higher group velocity in the thinning region, and the reason is attributed to the fact that the wall thickness here is smaller than the value of the cut-off thickness with the given operating frequency. The T(0,1) mode converts back into the T(0,2) mode when the thickness returns to the original after passing the thinning region. This finding of the mechanism for mode conversion is similar to the case of SH wave propagation in a plate waveguide,<sup>1,2</sup> and it implies the possibility of group velocity change caused by mode conversion for pipe inspection.

### References

1. Nurmalia, N. Nakamura, H. Ogi and M. Hirao: *Jpn. J. Appl. Phys.* **50** (2011) 07HC17.
2. Nurmalia, N. Nakamura, H. Ogi, M. Hirao and K. Nakahata: *NDT&E Int.* **45** (2012) 156
3. M. Hirao and H. Ogi: *EMATs for Science and Industry—Noncontacting Ultrasonic Measurements* (Kluwer Academic, Boston, MA, 2003), 47.
4. Nurmalia, N. Nakamura, H. Ogi and M. Hirao: in preparation for publication.