

Large Volume Coagulation Utilizing Multiple Cavitation Clouds Generated by 32 Channel Drive Circuits

32ch 駆動回路を用いたマルチキャビテーションクラウドの同時生成による広範囲焼灼法

Kotaro Nakamura[‡], Ayumu Asai, Keisuke Takada, Hiroshi Sasaki, Hiroki Okano, Shin Yoshizawa, and Shin-ichiro Umemura (Tohoku Univ.)

中村高太郎[‡], 浅井歩, 高田啓介, 佐々木博史, 岡野裕樹, 吉澤晋, 梅村晋一郎 (東北大)

1. Introduction

Japan is rapidly aging, and its currently leading cause of death is cancer, whose minimally invasive treatment is therefore favorable.

HIFU (High Intensity Focused Ultrasound) treatment, in which focused ultrasound is generated outside the body by a transducer and coagulates a diseased tissue at the focus, can be such a noninvasive treatment. The advantage of this method is minimal physical and mental stress because a patient need not to receive incision at all. On the other hand, the disadvantage of this method is the long treatment time caused by the small therapeutic volume (3x3x10 mm at 1.0 MHz for 10 s) by a single exposure. For example, 2 to 3 hours is needed to treat a prostate cancer 30 mm in diameter. An improved method with higher efficiency is needed.

To improve the efficiency, we are focusing attention on utilizing cavitation bubbles. Acoustic cavitation is the phenomenon in which microbubbles are generated by ultrasound. The generated microbubbles can convert acoustic energy into heat at a high efficiency. In this study, we proposed a new method to coagulate a large volume by a single HIFU exposure by generating cavitation bubbles distributing in the large volume and vibrating all of them.

2. Materials and Methods

2.1. Class D amplifier

A class A amplifier, which can amplify the input signal cleanly but is bulky, has been used for HIFU treatment. Because of its size, it is not suitable for driving an array transducer with a number of elements.

We therefore have developed a compact class D amplifier [1]. **Fig.1** shows its circuit diagram. This outputs square waves by changing the on/off state of MOSFETs (MTB2P50, ON Semiconductor and FDP5N50, Fairchild). The signals to change their on/off state were generated by FPGA boards (Spartan 3A starter kit, Xilinx).

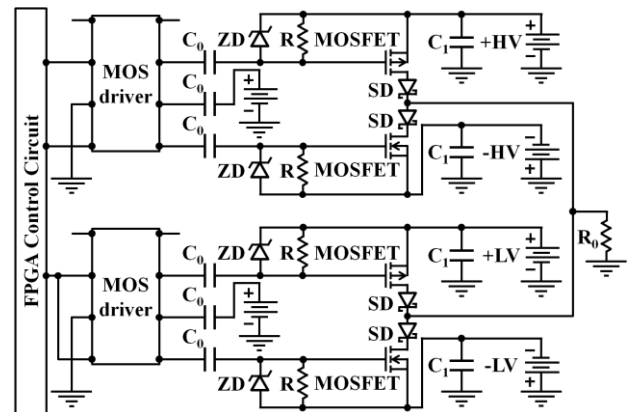

Fig.1. Drive circuit diagram

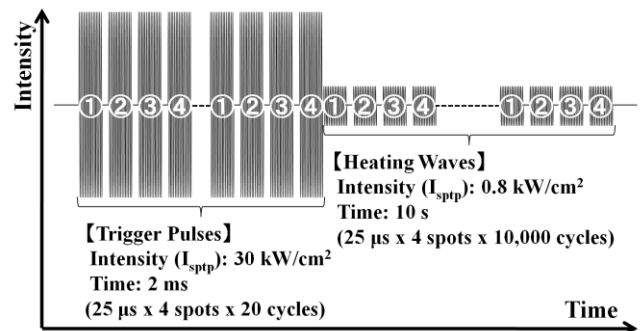

Fig.2. Irradiation sequence for Triggered HIFU

2.2. HIFU exposure

The method, we named “Triggered HIFU”, was used to enhance the heating effect by utilizing cavitation bubbles [2]. **Fig.2** shows the irradiation sequence. In this method, ultrasound pulses, called “Trigger Pulse”, with much higher intensity than the conventional HIFU, for a few microseconds to milliseconds, generate cavitation bubbles first. Then ultrasound waves, called “Heating Waves”, at lower intensity than the conventional HIFU, for a few to ten seconds, make the cavitation bubbles vibrate and enhance the heating effect of ultrasound.

In this study, the Triggered HIFU was exposed at 4 points simultaneously. We used the array transducer (Imasonic) for moving the focal point within the life time of cavitation bubbles

k_nakamura@ecei.tohoku.ac.jp

(typically, tens of milliseconds). The transducer was driven at 1.0 MHz. The intensity of the Trigger Pulses was 30 kW/cm^2 , and that of the Heating Waves was 0.8 kW/cm^2 (I_{spip}). The transducer irradiated ultrasound every $25 \mu\text{s}$ sequentially among 4 focal spots. The Trigger Pulses were exposed for 2 ms and the Heating Waves were exposed for 10 s in total. The case without Trigger Pulses and the case which ultrasound was irradiated at a single spot were performed as experiments to compare. The single spot exposure at 0.8 kW/cm^2 was continued for 2.5 s.

2.4. Experimental setup

Fig.3 shows the experimental setup in this study. The water in the tank was kept at 35°C and degassed (DO: 20%). The array transducer was connected to 32-channel drive circuits controlled by FPGA boards and driven by them.

Irradiated subjects were either acrylamide gel or excised chicken breast. The gel contained 8% of BSA (Bovine Serum Albumin, Sigma-Aldrich). The breast tissue was degassed in normal saline for 8 hours. The temperature rise at the center of the 4 focal points in the gel was measured by a thermocouple 0.3 mm in diameter (NCF600, CHINO).

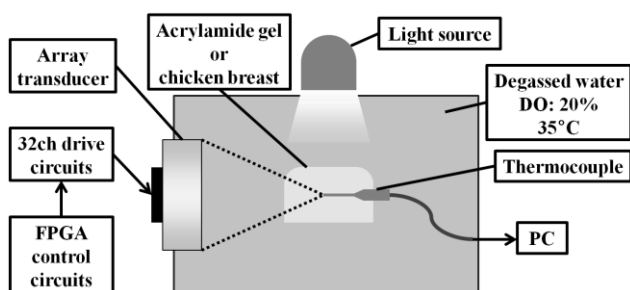

Fig.3. Schematic of experimental setup

3. Results and Discussion

Fig.4 shows the average temperature rise at the center of the 4 focal points in the cases with and without the Trigger Pulses ($n = 5$). The difference between these cases regarding the maximum temperature was 1.64 times although that regarding the acoustic energy was merely 0.75% and that regarding the irradiation time was merely 2 ms.

Fig.5 shows the average thermally coagulated volume of chicken breast for each irradiation sequence ($n = 5$). The differences between each case are significant ($p < 0.01$). The total acoustic energy of the case without the Trigger Pulses is 4 times that of the case with a single spot. Nevertheless, the coagulated volume of the case without the Trigger Pulses was significantly more than 4 times as large as that of the case with a single

spot. This is because the tissue at the center of the 4 focal points was coagulated by heat conduction from the 4 focal points. The coagulated volume of the case with the Trigger Pulses was 1.62 times as large as that of the case without the Trigger Pulses, which clearly shows the enhancement of the heating effect of ultrasound by cavitation bubbles around each focal spot.

4. Conclusions

In this study, we proposed the new method employed Triggered HIFU to coagulate a large volume and the obtained results showed its superiority over conventional methods.

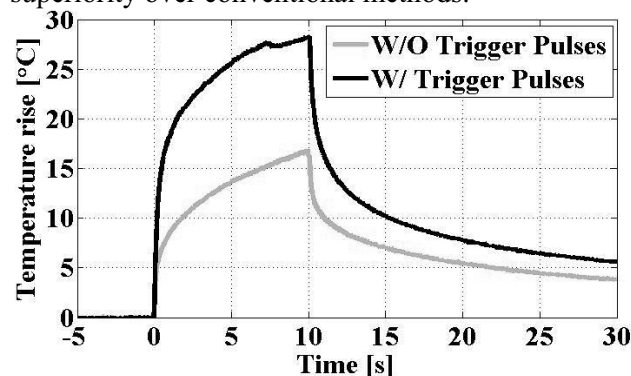

Fig.4. Average temperature rise at the center of the 4 focal points ($n = 5$)

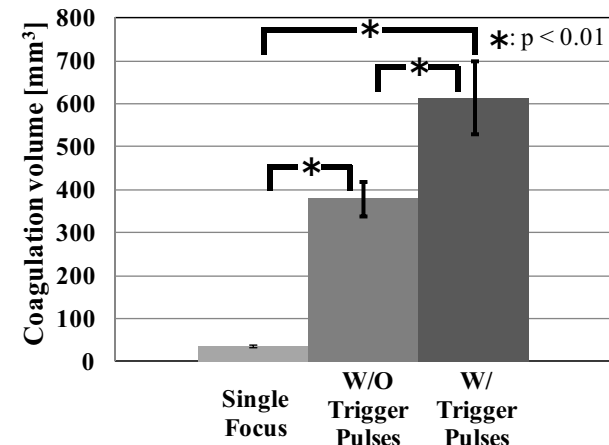

Fig.5. Average thermally coagulated volume of chicken breast ($n = 5$)

Acknowledgment

This research is supported by the Japan Society for the Promotion of Science (JSPS) through its Funding Program for World-Leading Innovative R&D on Science and Technology (FIRST Program).

References

1. K.Moro, S.Yoshizawa, S.Umemura: Jpn. J. Appl. Phys. **49** (2010) 07HF04
2. Y.Inaba, T.Moriyama, S.Yoshizawa, S.Umemura: Jpn. J. Appl. Phys. **50** (2011) 07HF13