

Method for Improving Quality Factor in Crystal Oscillators with Duplicated Quartz Resonators

2つの水晶振動子を用いた発振回路のQ値改善法

Ryou Suzuki^{1,†}, Katsuaki Sakamoto², and Yasuaki Watanabe³

(^{1,3}Grad. School of Sci. and Eng., Tokyo metropolitan Univ.; ²Nihon Dempa Kogyo)

鈴木 瞭^{1,†}, 坂元 克明², 渡部 泰明³ (^{1,3}首都大院 理工, ²日本電波工業)

1. Introduction

Quartz oscillators are widely used as stable frequency sources in communication systems. Advancements in mobile communications technology require quartz oscillators to perform low-phase noise characteristics. Much effort has been made to reduce oscillator phase-noise by contriving various circuit designs.

We developed a method for analyzing phase noise of the Colpitts crystal oscillator. We have conducted network analysis using the non-linear diode model and the phase noise analysis using the Leeson model in Colpitts oscillation circuit with duplicated quartz crystal units [1]-[3].

In this paper, we formulate the circuit impedance to apply to various oscillation circuits. From this analysis, good balance and interaction of the two crystal resonators and other circuits improve the circuit quality factor Q.

To evaluate circuit Q, the slope of circuit reactance is used. Moreover, the formularization of circuit reactance must be comparable among many circuits, which have many loops and high quality factor elements. Accordingly, we calculate the impedance expected from the output loop, because phase noise is observed at output in every oscillator.

2. Method for evaluating circuit Q

When we analyze phase noise, the Leeson model is generally used. However, this Leeson model applies to a circuit that has one circuit loop containing an amplifier and feedback of one

resonator. Furthermore, the definition of Q in the Leeson model is loaded Q of only one resonator. In an ordinary Colpitts oscillation circuit, a part of the circuit, except the crystal resonator, can approximate the amp of the Leeson model, and loaded Q of the crystal resonator can be utilized as Q value of Leeson's formula. However, our circuit has two duplicated crystals as the resonator, which are separately set. Hence, since the approximation cannot be applied to our circuit and various other circuits, we devised a method for evaluating the quality factor that can be compared between any oscillation circuit.

Therefore, we define Q of Leeson's formula as that of the entire oscillation circuit (namely, circuit Q). Circuit Q is estimated using

$$Q_{OSC} \propto \left. \frac{\partial \text{Im}(Z_{OSC})}{\partial \omega} \right|_{\omega=\omega_0} \quad (1)$$

Where ω_0 is the oscillator frequency, and Z_{OSC} is circuit impedance.

3. Formularization of circuit impedance

In the previous chapter, Evaluating method for evaluating circuit Q is discussed. We discuss the method for calculating circuit impedance is considered. Circuit impedance is calculated by deviding the circuit at an appropriate point and summing impedances on both sides of that deviding point. It is important where the deviding point is that varies value of circuit impedance.

Figure 1 shows the equivalent circuit of the Colpitts oscillator. In previous studies, the deviding

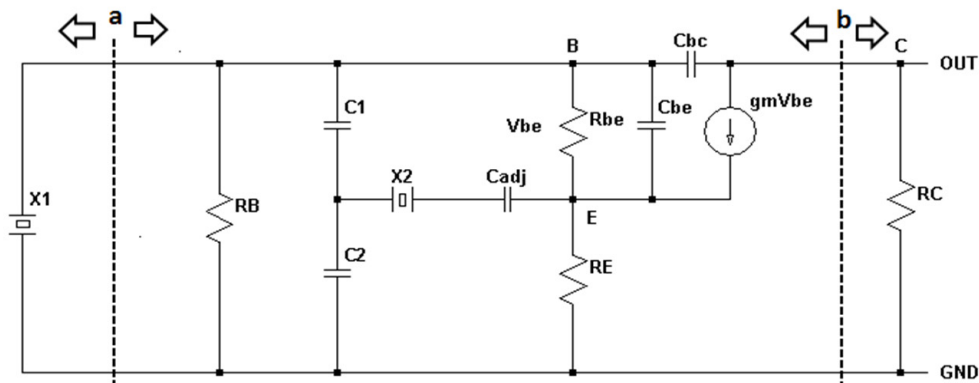

Fig. 1 Equivalent circuit of Colpitts oscillator

point was determined as “a” in Fig. 1. Since the Colpitts oscillation circuit approached one circuit loop with the Leeson model from this determination and the crystal resonator seems to be connected to that amplifier in series, we can easily obtain the behavior of circuit impedance by varying frequency. However, this determination cannot be fit to every oscillation circuits. In other words, the determination is not comparable with other circuits. The oscillator output where phase noise is

Table 1. Parameters of quartz crystal.

$R_q[\Omega]$	$L_q[\text{mH}]$	$C_{q1}[\text{fF}]$	$C_{q0}[\text{pF}]$	Q
8.836	0.368	6.875	2.028	26×10^3

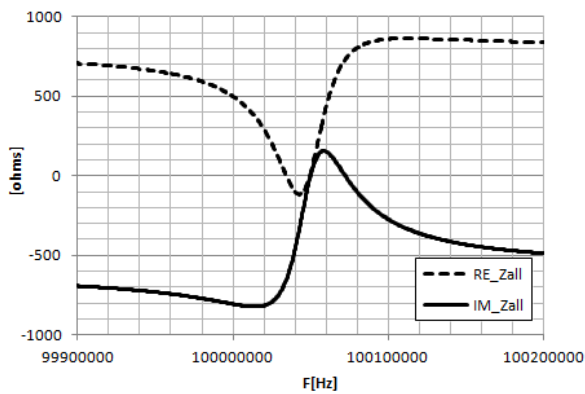

Fig. 2 Impedance characteristics of Colpitts oscillator with one quartz resonator

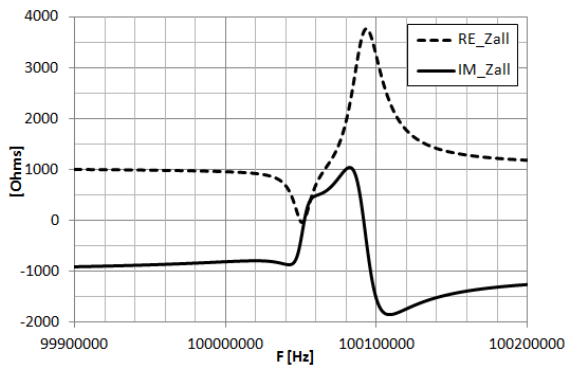

Fig. 3 Impedance characteristics of Colpitts oscillator with duplicated quartz resonators

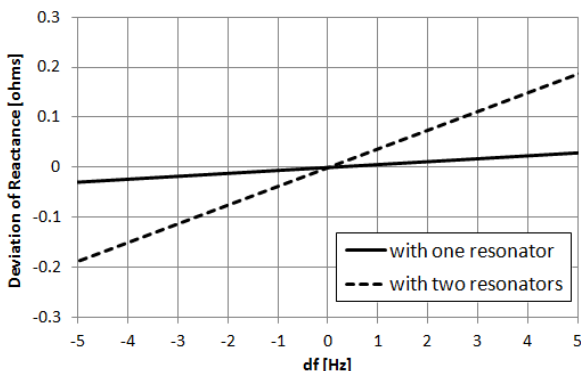

Fig. 4 Improvement in deviation of circuit reactance

observed is the point that can be defined in every oscillator. The circuit impedance and circuit Q can be compared among various oscillators by defining the devidng point as the oscillator output.

Based on this approach, we define the devidng point as “b” in Fig. 2 and formularized circuit impedance.

4. Analysis of circuit impedance characteristics in Colpitts oscillation circuit

Frequency characteristic of circuit impedance in steady state is solved by the new formulation of circuit impedance. The electrical paramaters of quartz crystal used in the analysis are listed in Table 1. The quarz crystal is AT-cut and resonates at 100 MHz. Figure 2 shows the of impedance characteristics in the Colpitts oscillation circuit with one crystal resonator, and Fig. 3 shows the characteristic of impedance with two duplicated crystal resonators. Adding a resonator causes a transformation of characteristics and steeper deviation of reactance. Figure 4 shows that addition of a nesonator increased the deviation of reactance by a factor of 4.2, therefore, circuit Q was increased by a factor of 4.2.

5. Conclusions

The characteristic of circuit impedance in the Colpitts oscillation circuit is formularized by defining the devidng point as the output loop to compare various oscillation circuits. The formularization enables the caluculation of the improvement in circuit Q by adding a crystal resonator.

We use duplicated AT-cut crystal resonators for every resonator in the Colpitts oscillation circuit. For future work, we will use SC-cut crystal resonators, which have higher Q than AT-cut resonators and compare the Colpitts and other oscillation circuits.

References

1. T. Uchida, M.Koyama, Y. Watanabe, H. Sekimoto and Y. Oomura: “A low phase-noise oscillator design for high stability OCXO’s”, Proc.1996IEEE Int. Frequency Control Symp., pp. 749-751,(1996)
2. Y. Watanabe, S. Komine, S. Goka, H. Sekimoto and T. Uchida: “Near-carrier phase-noise characteristics of narrow band Colpitts oscillator”, Proc.2004 IEEE Int. Frequency Control Symp., pp. 457-461,(2004)
3. D. B. Leeson: “A simple model of feedback oscillator noise spectrum”, Proc.IEEE, Vol.54, pp.329-330 (1966)