

Development of microscopic photothermal heterodyne interferometric detection method combined with a micro-HPLC for highly sensitive analysis

高感度分離検出のための micro-HPLC/顕微光熱変換ヘテロダイン干渉法の開発

Makoto Fukuma[†], Miki Isoda, Akira Harata
(Interdisciplinary Grad. School of Engineering Science, Kyushu Univ.)
福間誠[†], 磯田美紀, 原田明 (九大院 総理工)

1. Introduction

Bio-related substances are deeply relating to human health and life activities. Analysis of these substances have given important information to researchers in the medical science, biological technology, and clinical field.

The fluorescence derivatization methods have been used for non-fluorescent substances because of natively non-fluorescent character for a lot of bio-related substances. Previously, sensitive detection of peptides with a high performance liquid chromatography (HPLC) is generally performed under a precolumn or postcolumn derivatization condition.^{[1][2]} However, precolumn and postcolumn derivatization needs a complicated procedure with unexpected reaction causing low repeatability. Moreover, derivatization method cannot detect raw chemical substances. A non-label based and highly sensitive method is necessary for bio-related materials.

As a non-label based detection, direct determination is successfully demonstrated of non-labeled amino acids by using micro-HPLC with ultraviolet-excitation thermal lensing detection,^[3] although improvement in sensitivity has been required.

In this research, a microscopic photothermal heterodyne-interferometric (PHI) detection method combined with micro-HPLC separation is newly developed and applied to separation-detection of water-soluble vitamins (folic acid, riboflavin and cyanocobalamin).

2. Experimental

2.1 Setup for photothermal heterodyne-interferometric detection

Figure 1 schematically shows experimental setup. After separation with a micro-HPLC,

E-mail: fukuma.makoto.840@s.kyushu-u.ac.jp

photo-absorbing chemicals in the eluent flow into a sample cell(18nl,Cat.No.6001-70167) and is excited by an intensity modulated pump beam emitted from a semi-conductor laser (375nm). A He-Ne laser (632.8nm) is used as a probe beam to precisely monitor refractive index change caused by heat released. The probe laser beam is divided into two paths by a beam splitter. Optical frequencies of these beams are shifted differently with two acousto-optic modulators. One of the two beams transmits the sample solution with the pump beam collinearly illuminating, and is subjected to a phase shift caused by heat-induced refractive index change. By combining two probe beams on a photodetector, a beat signal at a frequency of the difference between the two optical frequencies is monitored for the phase shift. Magnitude of the phase shift with the intensity modulation is detected with a lock-in amplifier.

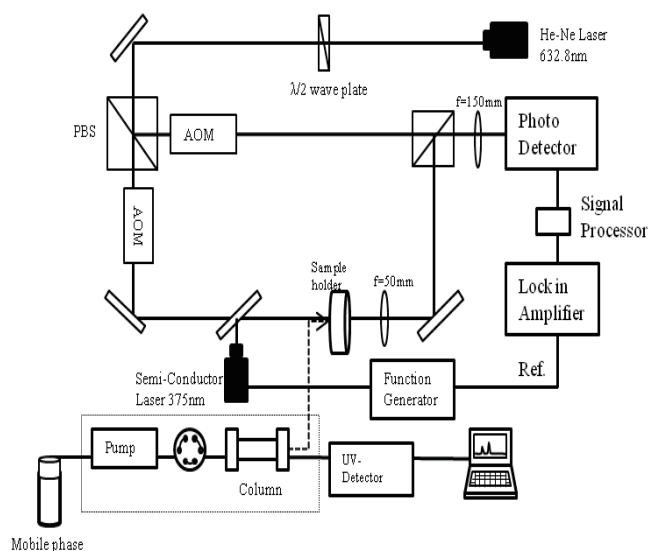

Fig. 1 Experimental setup

2.2 Chromatographic condition

Liquid chromatographic analysis of water soluble vitamins was performed on a micro-HPLC system (micro21-LC-01; Jasco.co) equipped with an

Table II. Detection limit of folic acid

	Excitation Wavelength (nm)	Absorptivity (ϵ)	Detection limit		Optical path length (mm)	Inject amount	Absolute quantity	Cell volume
			Concentration (μM)	Abs. (AU)				
UV	270	18436	8.2	1.2×10^{-1}	8	8.2pmol	130fmol	16nl
PHI*	375	4651	0.061	1.4×10^{-4}	5	61fmol	15fmol	250nl

*PHI ...Photothermal Heterodyne Interferometer

UV-detector (micro21-UV-01; Jasco.co) An auto sampler (micro21-AS-01; Jasco.co) was used for injection. A separation column of MERCK MILLIPO-RE (Tokyo,Japan) SeQuant ZIC HILIC (150mm \times 1mm, 5 μm particle size) was used for the analytes. Quantitation of the solutes was based on the absorbance maxima of each vitamin. Detection wavelengths were chosen: riboflavin, 267nm; folic acid, 280 nm; and cyanocobalmin, 270nm. The mobile phase of the HPLC system are as follows: *solvent A*, acetonitrile and 30mM phosphate buffer, pH6.0; 50:50 (v/v), *solvent- B*, acetonitrile and 30mM phosphate buffer; pH6.0; 90:10 (v/v) . Injection volume is 1 μL . Column temperature is 30.0 $^{\circ}\text{C}$. Sample concentrations are $1.0 \times 10^{-4}\text{M}$ for riboflavin and folicacid and $3.0 \times 10^{-5}\text{M}$ for cyanocobalamin.

3. Results and discussion

Figure 2 shows chromatograms of vitamins: riboflavin, folic acid and cyanocobalmin detected with the photothermal detector. Table I summarizes chromatographic data of each vitamins. Retention times of each vitamin are 8.8 min, 11.2 min, and 27.1 min, respectively. Resolution values of each peak are 1.8 and 9.8, which means good separations because it is general that if the resolution values are lower than 1.5, separations is not enough. Table II summarizes detection limits of UV detector and PHI for folic acid. Detection limit in concentration of PHI is $6.1 \times 10^{-8}\text{M}$, which is over two order of magnitude better than that of UV detector, $8.2 \times 10^{-6}\text{M}$. Detection limit in injection amount of the photothermal heterodyne-interferometer 0.15fmol is

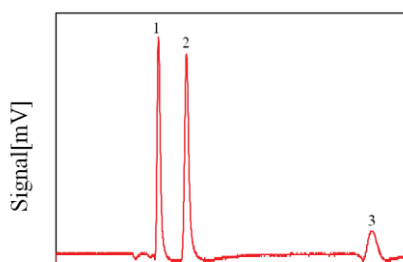

Fig. 2 Chromatogram of photothermal signal for three kinds of vitamins 1)riboflavin, 2)folic acid, 3)cyanocobalamin ,Cell volume:18nl

two order of magnitude better than that of UV detector, 0.13pmol.

TableI. Chromatographic data of vitamins

No.	Sample	C[M]	Retention Time(min)	Resolution
1	Riboflavin	$1.1 \times 10^{-4}\text{M}$	8.8	1.8
2	Folic acid	$1.0 \times 10^{-4}\text{M}$	11.2	9.8
3	Cyanocobalamin	$3.0 \times 10^{-5}\text{M}$	27.1	

4. Conclusion

A microscopic photothermal method combined heterodyne-interferometric detection with micro-HPLC separation is newly developed. Separation-detection is successfully demonstrated with HILIC column of three kinds of vitamin: riboflavin, folic acid, and cyanocobalamin. Good resolution was observed for each peak. Detection limits of the photothermal heterodyne-interferometer in concentration and in injected amount are two order of magnitude better than UV detector. Use of shorter wavelength-ultraviolet light for excitation will make detection of almost all of bio-related substances possible. There still remains some rooms of improvement of the equipment such as the use of smaller sample cell to suppress influence of diffusion, but this method is promising as a new separation analysis of bio-related substances.

Acknowledgment

A method for heterodyne-interferometric detection of photothermal signal developed by Kobe Steel, Ltd, was used.

References

1. J. Li, Q.Yan, Y. Gao, H. Ju, Anal Chem. **78** (2001)2694-2699
2. D. Shanguan, Y. Zao, H. Han, R. Zhao, G. Liu, Anal. Chem. **73** (2001) 2054-2057
3. H. Katae, S. Hirashima, A. Harata, Chromatography, vol.**29**(2008)Suppl.2,pp.5-6