

## Temperature compensation of ball SAW sensor by two-frequency measurement using undersampling

### アンダーサンプリングを用いた二周波数測定による ボール SAW センサの温度補償

Toshihiro Tsuji<sup>†</sup>, Toru Oizumi, Nobuo Takeda, Shingo Akao, Yusuke Tsukahara, and Kazushi Yamanaka (Tohoku Univ.)

辻 俊宏<sup>†</sup>, 大泉 透, 竹田 宣生, 赤尾 慎吾, 塚原 祐輔, 山中 一司 (東北大)

## 1. Introduction

Ball surface acoustic wave (SAW) sensor, that amplify the delay time change due to sensitive film using multiple-roundtrip propagation [1], can realize precise temperature compensation by two-frequency measurement (TFM) [2]. It is expected to realize practical highly sensitive gas sensor [1,3]. For precise phase measurement, we performed a wavelet analysis of the waveform after oversampling (OS) to Nyquist frequency  $f_N$  [1-3] or a digital quadrature detection of down-converted waveform by heterodyne detection [1,4]. However, the measurement systems using an analog-digital converter (ADC) with high sampling rate or heterodyne circuit with multi oscillators and nonlinear devices are expensive. On the other hand, although undersampling (US) less than  $f_N$  [5] could simplify TFM system, the applicability of an aliasing response to the sensor is not clear. In this study, we aim to develop a TFM system using US for practical temperature compensation of ball SAW sensor.

## 2. Principle of TFM system using US

A block diagram of TFM system using US is shown in Fig.1, where  $f_1$  and  $f_s$  are fundamental frequency

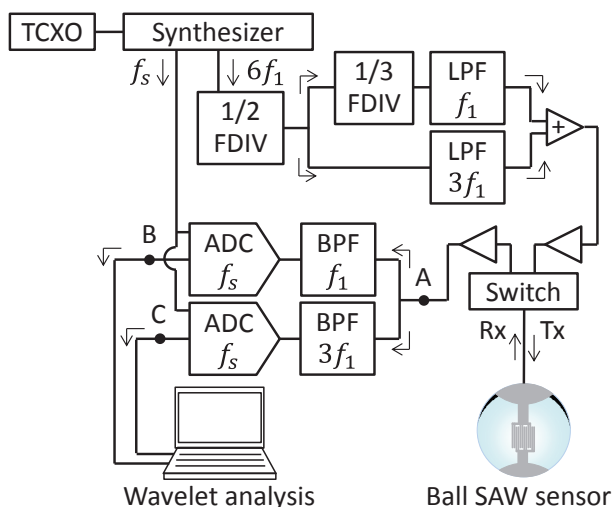

Fig. 1 Block diagram of TFM system of ball SAW sensor using US.  $f_1$  and  $f_s$  are fundamental frequency of sensor and sampling frequency of ADC, respectively.

of the sensor and the sampling frequency of ADC, respectively. A synthesizer synchronously generates a clock of  $f_s$  and a burst signal of  $6f_1$ . The latter is converted to the signals of  $f_1$  and  $3f_1$  by frequency dividers, and these signals are combined in phase as the transmission signal. The reflection signal is processed by narrow band-pass filters (BPF) with center frequencies  $f_c$  of  $f_1$  or  $3f_1$  and recorded by ADCs. In the case of  $f_s = 5f_1/4$ , signal frequency of  $|f_1 - f_s| = f_1/4$  and  $|3f_1 - 2f_s| = f_1/2$  are generated by the aliasing. Finally, the wavelet analysis is applied to these frequency components [3].

## 3. Experimental method

A harmonic quartz ball SAW sensor (3.3 mm in diameter,  $f_1 = 80$  MHz), coated by sol-gel silica film for trace moisture measurement [3], was measured by a broadband pulsar/receiver and the waveform was recorded using OS (5 GHz, 1024 averaging). To simulate the US at  $f_s = 100$  MHz, the data were extracted at intervals of 50 after BPF with 5% width of  $f_c$  (4 MHz). The wavelet analyses using Gabor function ( $\gamma = 50$ ) were performed at  $f_1$  or  $3f_1$  in the case of OS and at  $f_1/4$  or  $f_1/2$  in the case of US. The delay time was measured from the difference between those of the 3<sup>rd</sup> and 7<sup>th</sup> turns.

## 4. Results

### 4.1 Change in waveform by US

The waveforms at positions B and C in Fig.1 were obtained from US of OS waveform A (7<sup>th</sup> turn, Fig. 2).

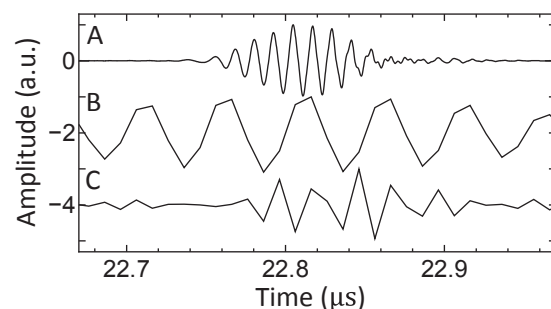

Fig. 2 Waveforms at positions A-C in Fig. 1. A is OS waveform (7<sup>th</sup> turn). B and C are simulated by US.

Corresponding power spectra are shown in Fig. 3. The frequency components of  $f_1$  and  $3f_1$  were confirmed in the case of OS (Fig. 3(a)) and those of  $f_1/4$  and  $f_1/2$  in the case of US (Fig. 3(b)).

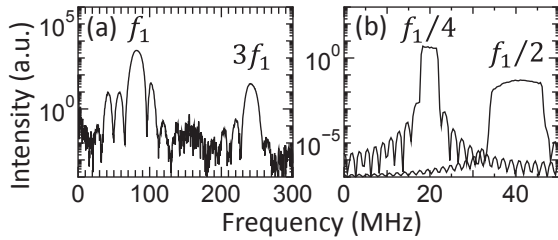

Fig. 3 Power spectra of (a) waveform A and (b) those of B and C, shown in Fig. 2 ( $f_1 = 80$  MHz).

#### 4.2 Application to trace moisture measurement

A trace moisture measurement (4-790 nmol/mol) using OS is shown in Fig. 4. In Fig. 4(a), dotted and solid curves represent delay time of  $f_1$  and  $3f_1$ , respectively. Fig. 4(b) shows the result of subtraction of  $f_1$  data from those of  $3f_1$  using a coefficient of 1.0. As a result, the response to the moisture became clear, where the response from 4 nmol/mol to 17 nmol/mol was measured by S/N of 44.8.

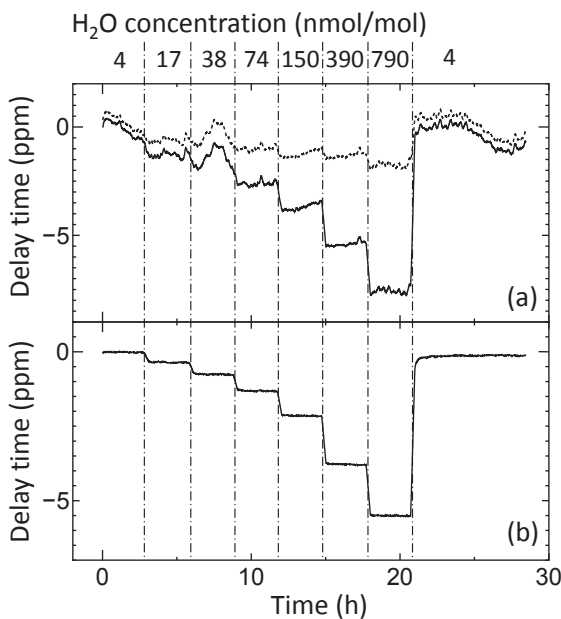

Fig. 4 Temperature compensation with  $f_1$  and  $3f_1$  using OS. (a) Solid and dotted curves show outputs of  $f_1$  and  $3f_1$ , respectively. (b) Compensated output of  $3f_1$  subtracted by that of  $f_1$  using coefficient of 1.0.

Next, the result of US is shown in Fig. 5. Dotted and solid curves in Fig. 5(a) represent delay time of  $f_1/4$  and  $f_1/2$ , respectively, where the polarity of  $f_1/4$  was inverted due to  $f_1 < f_s$ . When the data of  $f_1/2$  was subtracted by that of  $f_1/4$  using a coefficient of -1.5 (Fig. 5(b)), the temperature

compensation similar to Fig. 4(b) was obtained, where the response was matched with that of OS by linear function with a correlation coefficient  $|R|$  of 0.9999.

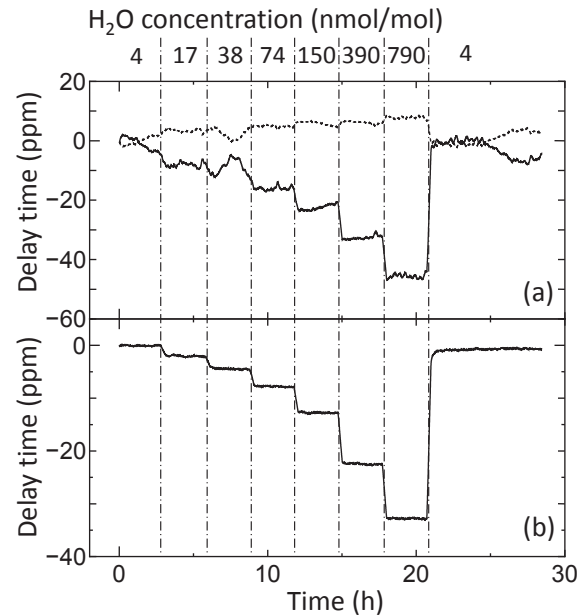

Fig. 5 Temperature compensation with  $f_1/4$  and  $f_1/2$  using US. (a) Solid and dotted curves show outputs of  $f_1/4$  and  $f_1/2$ , respectively. (b) Compensated output of  $f_1/2$  subtracted by that of  $f_1/4$  using coefficient of -1.5.

#### 4. Conclusion

It was shown that precise output of a ball surface acoustic wave sensor could be obtained even using undersampling, which was equivalent to that using oversampling. In future, we will develop the circuit shown in Fig.1 and install it in sensor products.

#### Acknowledgment

This work was supported by JSPS KAKENHI Grant-in-Aid for Young Scientists (A) 24686013.

#### References

1. K. Yamanaka, S. Ishikawa, N. Nakaso, N. Takeda, D. Y. Sim, T. Mihara, A. Mizukami, I. Satoh, S. Akao, and Y. Tsukahara, *IEEE Trans. Ultrason. Ferroelectr. Freq. Control* 53 (2006) 793.
2. T. Nakatsukasa, S. Akao, T. Ohgi, N. Nakaso, T. Abe, and K. Yamanaka, *Jpn. J. Appl. Phys.* 45 (2006) 4500.
3. S. Hagihara, T. Tsuji, T. Oizumi, N. Takeda, S. Akao, T. Ohgi, K. Takayanagi, T. Yanagisawa, N. Nakaso, Y. Tsukahara, K. Yamanaka, *Jpn. J. Appl. Phys.* 53 (2014) 07KD08.
4. T. Abe, N. Iwata, T. Tsuji, T. Mihara, S. Akao, K. Noguchi, N. Nakaso, D-Y. Sim, Y. Ebi, T. Fukiura, H. Tanaka, K. Yamanaka, *Jpn. J. Appl. Phys.* 46 (2007) 4726.
5. S. M. Kuo, B. H. Lee, *Real-time Digital Signal Processing* (John Wiley&Sons, Ltd, 2001, New York) 154.