

Intravascular Ultrasonic-Photoacoustic (IVUP) Imaging for Ex Vivo Lymph Node Detection and Characterization in Pig Esophagus

N.Q. Bui¹, T.H. Nguyen¹, H. Shin¹, K.K. Hlaing¹, H.H. Kim⁴, H.W. Kang^{2,3}, and J. Oh^{2,3}

(¹Interdisciplinary Program of Marine-Bio, Electrical & Mechanical Engineering, Pukyong Nat'l Univ., Busan, Korea; ²Department of Biomedical Engineering, Pukyong Nat'l Univ., Busan, Korea; ³Center of Marine-Integrated Biomedical Technology (BK21 Plus), Pukyong Nat'l Univ., Busan, Korea; ⁴Division of Gastroenterology, Department of Internal Medicine The Catholic Univ. of Korea College of Medicine Seoul St. Mary's Hospital Marine, Seoul, Korea)

1. Introduction

Lymph node imaging is an important prognostic factor in gastrointestinal cancer screening, which helps physicians differentiate lymph nodes from benign and malignant nodes. The accurate detection and characterization of the lymph nodes can ensure vital therapeutic and prognostic significance for patients with early diagnosed cancer before commencing therapy. In ex vivo study, we present a biomedical imaging modality that combined intravascular ultrasound (IVUS) with intravascular photoacoustic (IVPA) imaging for ICG detection in pig intestine with indocyanine green (ICG) injected and esophagus with phantom lymph node model sutured. The objective of the current study was to demonstrate that the combination of these imaging techniques - IVUP imaging, could provide structural information on the lymph nodes for precise screening.

2. Materials and methods

a. IVUP Imaging System

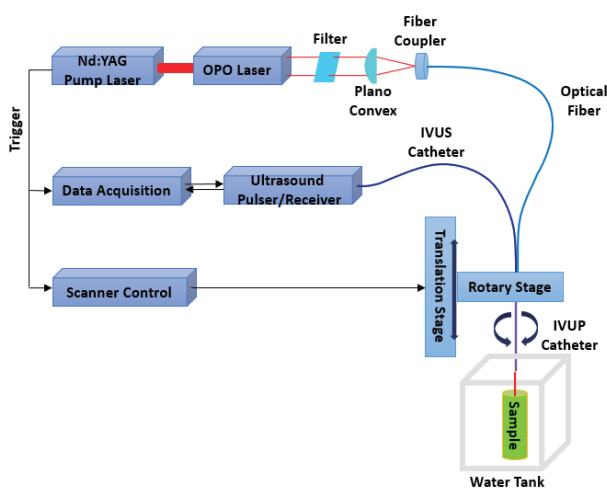

Fig. 1. Block diagram of IVUP imaging system.

Fig. 1 illustrates an experimental setup for IVUP imaging. For IVPA imaging, a Q-switched pulsed Nd:YAD laser operating at 10 Hz repetition rate (Surelite II, Continuum, San Jose, CA, USA)

was used with various wavelengths ranging from 650 to 1064 nm using an optical parametric oscillator (OPO) (Surlite OPO Plus, Continuum, San Jose, CA, USA). The pumping light was rejected with a high-pass filter, and the output laser beam was coupled into an 0.6-mm core multi-mode optical fiber (OF) with a plano-convex lens (PCL) (50 mm in focal length). The input end of OF was fixed in a fiber coupler that could rotate and constantly maintain OF at the focus point. The output end of OF was integrated with a 45-MHz IVUS transducer to form an IVUP catheter (Fig. 2).

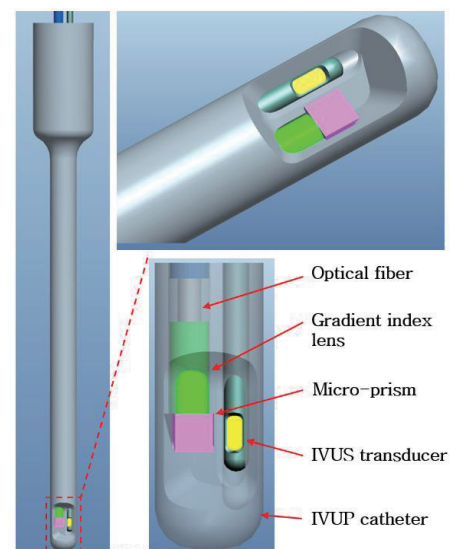

Fig. 2. Diagram of the IVUP catheter for experiments.

To irradiate the sample that was placed parallel to the imaging catheter, a combination of 1-mm diameter gradient index (GRIN) rod lens with 1-mm N-BK7 right angle micro-prism was used to change the direction of laser light. The IVUP catheter was connected to a gearbox of step motor-gearbox combo (rotary stage) to perform a B-mode scan by rotating the IVUP catheter in 360 degrees (counterclockwise) with respect to the central axis of the catheter. To prevent both OF and IVUS catheter from twisting each other, rotation in opposite direction (clockwise) was applied to obtain the next B-mode scan. The output signals from the

IVUS transducer was then amplified using an ultrasound pulser/receiver (5072 PR, Olympus, Waltham, MA, USA) before digitized by a 100-MS/s data acquisition card (PXI-5122, National Instruments, Austin, TX, USA), and finally recorded into two separate data set based on the rotary direction of the gearbox. To perform a 3D image, a series of B-mode scan was recorded step-by-step by longitudinally scanning the sample via another step motor (translation stage). A LabVIEW program was developed to control all the processes mentioned above. The acquired data was bandpass filtered using a linear-phase finite impulse response (FIR) digital filter, followed by Hilbert transform, and then converted to the polar coordinates for display by a custom-developed MATLAB® program.

b. IVUP Imaging of a Vessel Phantom

To evaluate the custom-built imaging system, a tissue-mimicking vessel phantom that was made from a mixture of 8% polyvinyl alcohol (PVA) (165SF) and 0.4% silica with ICG and MB inclusion was utilized. PVA was used as the material for vessel phantoms because of the non-toxic, easy casting and long-term storage, while silica particles (0.2 - 0.3 μm in diameter) was added to the PVA solution to mimic the ultrasound and optical scattering properties of tissues [1]. The fabrication of 12-mm diameter phantom, 4-mm diameter lumen with four compartments is shown in Fig. 3(a). To conduct an experiment, the IVUP imaging catheter was inserted into the lumen of the phantom which was placed inside a water tank. ICG and methylene blue (MB), the biological dyes used in medical diagnostics, were mixed with degassed water before injected alternately into the compartments. The lumen of phantom was filled with water degassing.

c. IVUP Imaging of Tissue Samples in Ex Vivo

To demonstrate the feasibility of ICG detecting by using this system, IVUP imaging were also performed on ex vivo sample of pig intestine with ICG injected and esophagus with phantom lymph node model sutured. The intestine and esophagus (with the thickness of 2 and 4 mm, respectively) were excised from a healthy pig. The PVA vessel phantoms were placed in the lumen of pig intestine and esophagus (with the diameter of 12 and 20 mm, respectively) to form the tubular samples before placed in the water tank.

3. Results

The results of IVPA and IVUP imaging of the

vessel mimicking phantom with ICG and MB inclusion are presented in Fig. 3(b) and (c), respectively. Both of the images are displayed over a 12-mm field of view. The cross section of cylindrical phantom containing four compartments is shown in Fig. 3(a).

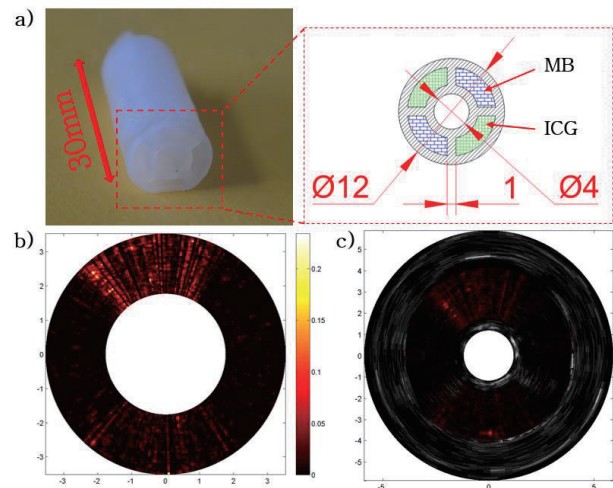

Fig. 3. (a) PVA phantom and the cross section with ICG and MB inclusion; (b) IVPA image; (c) IVUP image.

Fig. 4(a) shows the pig intestine with ICG injected and the PVA vessel phantom placed in the lumen. To perform a IVUP imaging (Fig. 4(b)), 300 ultrasonic and photoacoustic beams were acquired and 800-nm wavelength was used as the peak absorption of ICG.

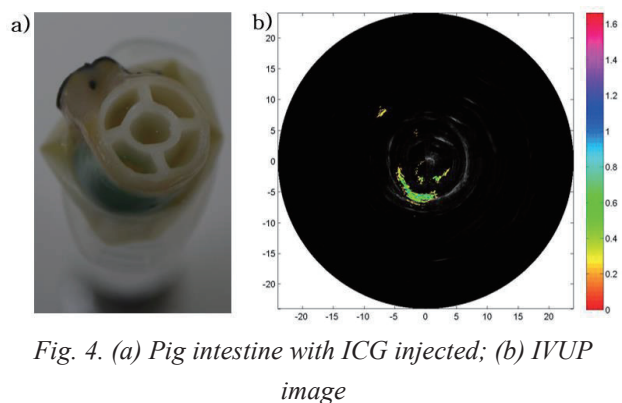

Fig. 4. (a) Pig intestine with ICG injected; (b) IVUP image

References

- Shriram Sethuraman et al. "Intravascular Photoacoustic Imaging Using an IVUS Imaging Catheter," IEEE Transactions on Ultrasonics, Ferroelectrics, and Frequency Control, vol. 54, no. 5, 2007.
- Bai X et al. "Intravascular Optical-Resolution Photoacoustic Tomography with a 1.1 mm Diameter Catheter," PLoS ONE 9(3): e92463. doi:10.1371/journal.pone.0092463, 2014.