

Destruction of tissue marker for gastrointestinal tumor localization by ultrasound irradiation

超音波照射による消化管腫瘍局在化のための組織マーカー破壊に関する研究

Ryosuke Yahagi^{1,†}, Kenzi Yosida², Yiting Zhang¹, Masahiko Ebata³, Taro Toyota⁴, Tadashi Yamaguchi², Hideki Hayashi² (¹Dep. of Medical System Eng. Grad. School Eng., Chiba Univ.; ²Center for Frontier Medical Eng., Chiba Univ.; ³Faculty of Eng., Chiba Univ.; ⁴Dep. of Basic Science, Grad. School of Arts and Science, The Univ. of Tokyo)

矢作 亮介^{1,†}, 吉田 憲司², 章 逸汀¹, 江島 将彦³, 豊田 太郎⁴, 山口 匡², 林 秀樹²
(¹千葉大院 工, ²千葉大フロンティア医工学センター, ³千葉大 工, ⁴東京大院 総合文化)

1. Background of this study

In laparoscopic surgery of gastric cancer, localizing tumors and deciding resecting lines are difficult because the surgeon cannot touch organs directly [1]. Therefore, we developed the tissue marker which encapsulates fluorescent liposomes and X-ray contrast agents wrapped in vesicles of amphiphilic molecules. In case of the surgery of gastric submucosa, the administration of the marker would enable to visualize not only ascertaining tumor locations during a surgery by near-infrared (NIR) fluorescence laparoscopy but also doing operating simulation with X-ray computed tomography (CT) [2]. Furthermore, we have the idea that the tissue marker might be used as a tracer to identify sentinel lymph nodes (SLN) if the marker structures are destroyed by ultrasound irradiation. We propose the destruction method using an ultrasonically activated device (USAD) and demonstrate the result of basic examination.

2. The structure of the tissue marker

The tissue marker is comprised of giant cluster-like vesicles that encapsulate ICG-C18 (indocyanine green derivatives) compounded liposomes and Lipiodol® (X-ray contrast agents) emulsion. The giant cluster-like vesicles (GCV) are made of polyglycerine polyricinoleate (PGPR).

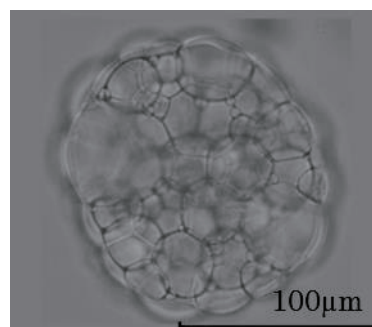

Fig. 1 Giant cluster-like vesicle

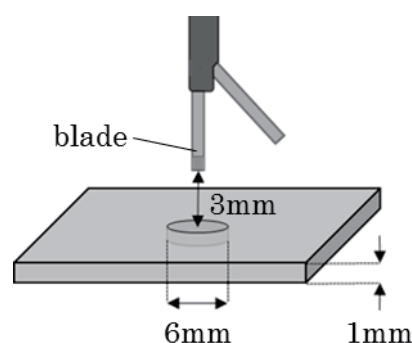

Fig. 2 The schematic view of the system for ultrasound irradiation using a USAD.

Since this study is a basic examination at the present stage, we used only GCVs which include nothing inside. **Fig. 1** shows an optical microscopic image of a GCV.

3. Methods

Fig. 2 shows the experimental systems of this study. A hole with diameter of 6 mm in 1-mm thick silicon plate was used as a cell for

containing the vesicular dispersion. To avoid the leakage of the dispersion, the cell was covered with glasses with thickness 0.12~0.17 mm in the surface/bottom of the cell. The cell was filled with $3.0 \times 10^{-2} \mu\text{l}$ of the dispersion. We used an USAD (Covidien, Sonicision) for ultrasound irradiation. The blade, which is equipped in the tip of USAD, vibrates at a frequency of 55.5 kHz. The blade was located at the point of 3-mm away from the surface of the cell in the tank filled with degassed water. The USAD was operated in different two modes; low power mode and high power mode. The displacement amplitudes of tip of the blade were $63.5 \mu\text{m}$ and $83.8 \mu\text{m}$ in low and high power mode, respectively. The USAD was running for one minute in both modes. Before and after the ultrasound irradiation, the state of GCVs was observed by the optical microscope (Nikon, Eclipse80i).

4. Results and Discussion

Figs. 3 and **4** show the pictures of the cells before and after ultrasound irradiation. Before the ultrasound irradiation, a number of vesicles were observed. Compared with picture after ultrasound irradiation, it was found that many vesicles were disappeared. This tendency was confirmed in both operation modes (low and high power mode), although there was almost no difference in the degree of destructions. In conclusion, this result suggests that most of vesicles were destroyed by using a USAD.

It is thought that the vesicles were destroyed by ultrasonic cavitation, not the primary action of the USAD blade. This is because the tip of the blade was not contact with the cell. A previous study demonstrated that cavitation bubbles were locally generated from the tip of the blade in degassed water as shown in **Fig.5** [3]. Based on the result, we suppose that the mechanical action of cavitation bubbles is a main cause of the destruction of vesicles.

5. Conclusion

We confirmed that most of vesicles were destroyed by ultrasound irradiation with USAD. In our future research, we will examine the relation between generating cavitation by the strength of ultrasound, time of irradiation, distance, etc. and destructing vesicles. In addition, we need to examine a lower invasive condition of destruction.

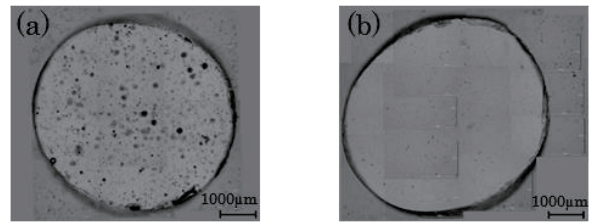

Fig. 3 The pictures of the cells (a)before and (b)after low power mode-irradiation

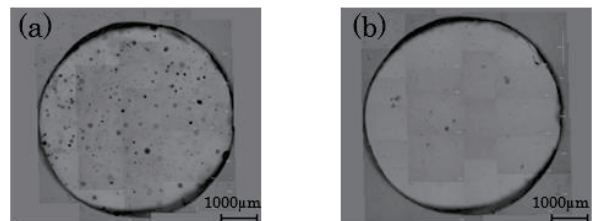

Fig. 4 The pictures of the cells (a)before and (b)after high power mode-irradiation

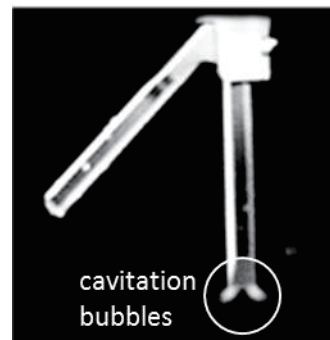

Fig. 5 Cavitation bubbles generated near the tip of the USAD blade.

Acknowledgment

This work was partially supported by Grant-in-Aid for Exploratory Research of Center for Frontier Medical Engineering, Chiba University.

Reference

1. H. Hayashi, T. Toyota and H. Matsubara: Surg. Endosc. 29 (2015) 1445-1451
2. H. Hatayama, T. Toyota, H. Hayashi, T. Nomoto and M. Fujinami: Anal. Sci. 30 (2014) 225-230
3. R. Narisawa, T. Yamaguchi, H. Hayashi and H. Hachiya: IEICE 23 (2010) 53-58