

The Effect of Divided Coefficient on the Equalizer for Underwater Acoustic Communication

Ming Chuai[†], Kyu-Chil Park, Jihyun Park, and Jong Rak Yoon
(Pukyong Nat'l Univ., KOREA)

1. Introduction

An underwater acoustic communication channel in shallow water, is known to be a multipath fading channel.¹⁻²⁾ This result in amplitude variation, phase change, and intersymbol interference (ISI)³⁻⁴⁾ in a transmitted signal. Therefore, the performance of the underwater acoustic communication system degrades owing to these channel distortions. To compensate for this, several techniques have been adopted like as a phase locked loop, the acoustic equalizers and so on in the underwater communication system. In this study, for the performance improvement, we evaluated the effect of dividing coefficients on the equalizer for a packet data transmission in shallow water with a QPSK system.

2. Experimental Conditions

Figure 1 shows the configuration of a sea experimental configuration, multipath intensity profile and its impulse response for the simulation. The specific experimental parameters are given in **Table I**. The range between the transmitter and the receiver is set to be 100 m, and the depths of the receiver and transmitter are set to be 7 and 10 m, respectively. We assumed that the channel response had only 5 multipath, namely, direct, bottom reflected, surface reflected, bottom-surface reflected, and surface-bottom reflected signals. The carrier and sampling frequencies are chosen as 16 and 128 kHz, respectively. The transmission rates are set to be 100, 400, and 1600 symbols per second (sps). The transmitted image is the standard Lenna image consisting of 35x35 pixels and 8 bits per pixel, which amounts to 9,800 bits of data.

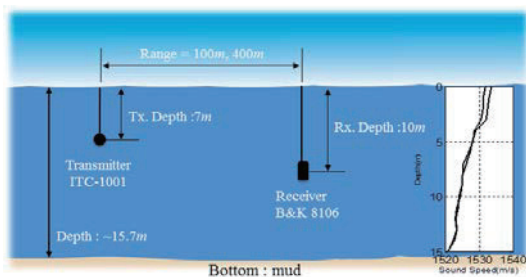

(a)

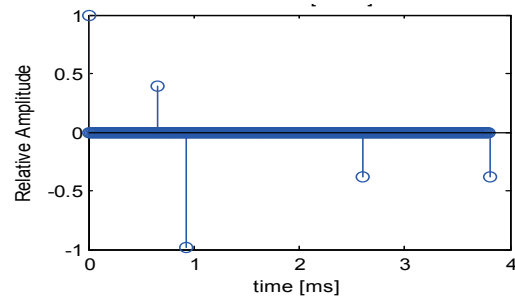

(b)

Fig. 1 Experimental configuration (a), and its impulse response obtained by the image method⁵⁾ (b).

Table I. Simulation and experimental parameters

Mod/Demod. System	QPSK
Carrier frequency (kHz)	16 kHz
Sampling frequency (kHz)	128 kHz
Symbol rates (sps)	100, 400, 1600
Data Transmission Type	Packet
Tx and Rx range (m)	100
Tx and Rx depth (m)	7, 10
Depth (m)	~15.7
Bottom property	Mud
Data (bits)	Image 9,800 bits

3. Numerical simulations and results

The channel's coherence bandwidth⁶⁾ was about 200 Hz at 100 m range from Ref. 7. It means that only transmitted signals at 100 sps belong to non-frequency-selective fading channels due to the scheme of the experimental environment, then in this symbol rate only a constant phase compensation or time delay is required. At other symbol rate, the multipath delay spread is more than about two symbol interval time and then an equalizer is required. The results in a constant phase compensation are shown in **Fig. 2** - top: before compensation, bottom: after compensation. Comparing the each result, only the error rate at 100 sps is improved. It means that the constant phase compensation technique is not working in the frequency-selective multipath fading channels. In other word, the constant phase compensation technique does not work if the multipath delay spread is larger than symbol interval.

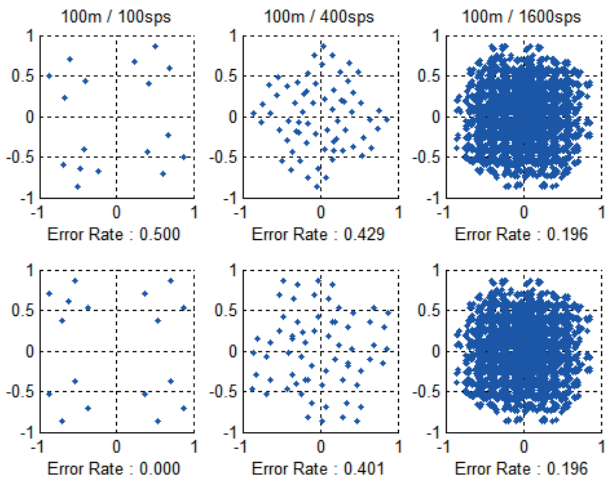

Fig. 2 Results of phase compensation.

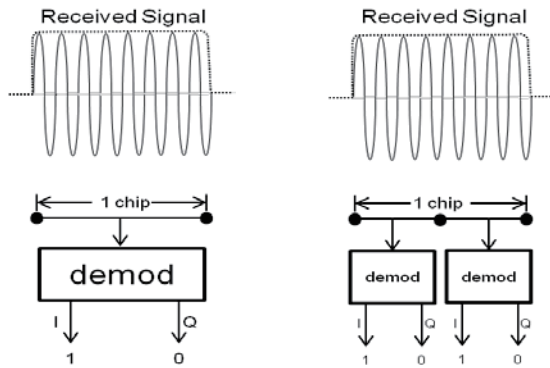

Fig. 3 The concepts of divided coefficient equalizer.

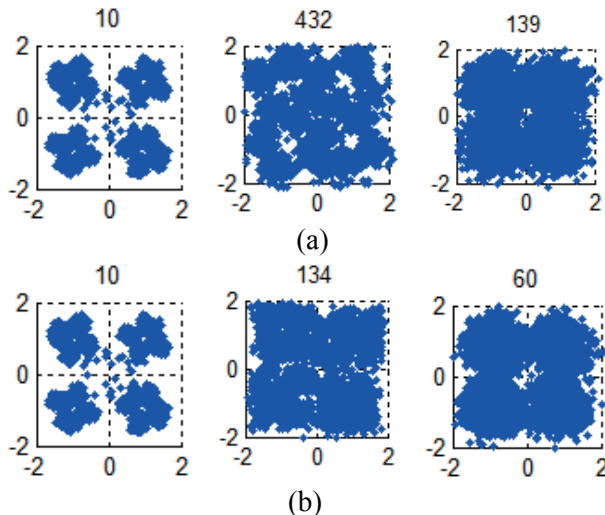

Fig. 4 Results of the equalizers with (a) and without (b) the divided coefficient equalizers.

In this study, the divided coefficient equalizer is proposed to estimate the channel impulse response. **Figure 3** shows the concepts of the divided coefficient equalizer. A chip signal in the QPSK modulation and demodulation system on non-divided coefficient equalizer has typically 1 symbol in each I and Q channels. In the divided

coefficient equalizer, a chip signal has 2 symbols, so that it would be better to estimate of the channel impulse response.

Figure 4 shows the results of the with and without the divided coefficient equalizer that is combined with the feed forward equalizer (FFE) and a normalized least mean square (NLMS) algorithm. The situations of simulations are exactly same with that of **Fig. 2**. The numbers of coefficients were chosen by 2, 2, and 4 at 100, 400, and 1600 sps, respectively. The length of the impulse response was 487 points, and the length of a chip signal were 1600, 400, and 80 points at 100, 400, and 1600 sps, respectively.

Comparing the each result, the error rates were decreased to about 0%, 30%, and 43% in the same amount of the coefficients, respectively. The error rate on the number of the coefficient were chosen by 3 and 4 on 400 sps, were decreased to about 116% (from 0.18% to 0.21%), and 90% (from 0.18% to 0.16%), respectively. The error rate on the number of the coefficient were chosen by 6 and 8 on 1600 sps, were decreased to about 55% (from 0.45% to 0.24%), and 125% (from 0.37% to 0.46%), respectively.

4. Conclusions

We introduced the divided coefficient equalizer to estimate the channel impulse response and to improve the performance of the underwater acoustic communication system. The error rate was significantly decreased in the just half divided coefficients. But, it is found that as the number of coefficient increases, performance improvement in the error rate is not significant. Proposed equalizer is more effective on low number of coefficients. For further study, it is required how the number of diving on a chip or non-equal length of dividing the coefficient is related to the multipath delay spread-to-symbol interval, and so on.

References

1. W. B. Yang and T. C. Yang, Proc. IEEE Oceans 2006, 2006, p. 1.
2. T. C. Yang, J. Acoust. Soc. Am. **131**, 129 (2012).
3. J. Park, J. R. Yoon, and J. Park, Jpn. J. Appl. Phys. **48**, 07GL03 (2009).
4. J. Kim, K. Park, J. Park, and J. R. Yoon, Jpn. J. Appl. Phys. **50**, 07HG05 (2011).
5. F. B. Jensen and W. A. Kuperman, *Computational Ocean Acoustics* (AIP Press, New York, 1994).
6. T. S. Rappaport, *Wireless Communications: Principles and Practice* (Prentice-Hall, NJ, 2002) 2nd ed., p. 400.
7. J. R. Yoon, K. Park, and J. Park, Jpn. J. Appl. Phys. **54**, 07HG05 (2015).