

## Harbor Demonstration of Underwater Acoustic Communication Using Doppler-resilient Orthogonal Signal Division Multiplexing

ドップラー広がり頑健な直交信号分割多重を用いる水中音響通信の港湾実験

Tadashi Ebihara<sup>1</sup>, Geert Leus<sup>2</sup>, and Hanako Ogasawara<sup>3</sup> (<sup>1</sup>Univ. Tsukuba; <sup>2</sup>TU Delft; <sup>3</sup>NDA)

海老原 格<sup>1†</sup>, ハート・ルース<sup>2</sup>, 小笠原 英子<sup>3</sup> (<sup>1</sup>筑波大, <sup>2</sup>デルフト工科大, <sup>3</sup>防衛大)

### 1. Introduction

Underwater acoustic (UWA) communication has been used for underwater operations, and the scope of its usage is still growing. For example, in new underwater projects, UWA communication is adopted to establish a complicated network that connects a number of sensors and underwater vehicles as hubs of the network. However, the UWA channel is a challenging environment because the channel suffers from large delay and Doppler spreads, whose effects are several times larger than those observed in radio communication.

To provide a reliable UWA link, we have proposed Doppler-resilient orthogonal signal division multiplexing (D-OSDM)<sup>1)</sup>. D-OSDM multiplexes several messages in addition to a pilot, and it has been designed to preserve orthogonality among them even after propagation through UWA channels with delay and Doppler spreads. We also have tested D-OSDM in simulations and test-tank experiments, and have found that D-OSDM achieved better communication quality than those of existing communication schemes, such as normal OSDM<sup>2-3)</sup> and Doppler-resilient orthogonal frequency division multiplexing (D-OFDM)<sup>4)</sup>. However, no experiments have yet been conducted in an actual environment.

The scope of this study is to evaluate the performance of D-OSDM in an actual environment. In this paper, we carry out UWA communication in a harbor to demonstrate the advantage of the proposed D-OSDM system, and evaluate its performance.

### 2. Experimental Conditions

**Fig. 1** shows the experimental setting and map of the experimental site. The experiment was conducted in Hashirimizu port, on 21 June, 2016. Throughout the experiment, the weather was rainy, and the sea state was calm (glassy). The transmitter (Tx) was fixed on a floating pier, and the receiver (Rx) was mounted on a remote control boat (RC-S1, Coden). By using the remote control boat, a Doppler spread with various input signal-to-noise ratios (ISNRs) was generated, as shown in **Fig. 2**. The remote control boat departs the pier to the central area of the port (approximately 70 m away from the pier), and returns to the pier with constant speed [about 1.4 kt (0.7 m/s)].

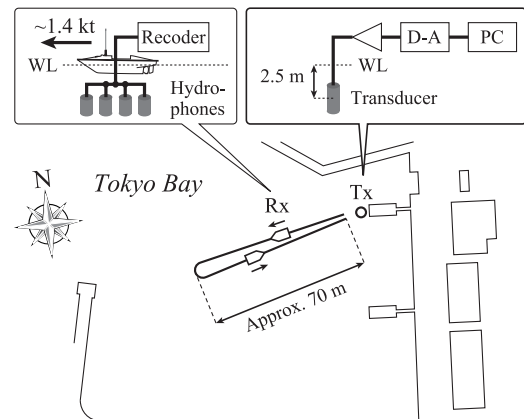

Fig. 1 Experimental setting and map of the experimental site.

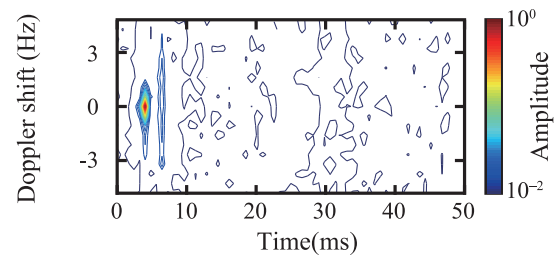

Fig. 2 Channel impulse response obtained in the experiment.

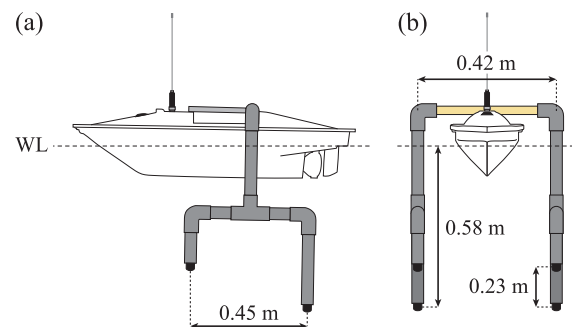

Fig. 3 Receiver settings: (a) side and (b) front view.

The Tx consists of a transducer (OST-2120, OKI seatec), amplifier (HSA4052, NF), digital-to-analog (D-A) converter (USB-6212, NI), and software modulator on a PC. The receiver (Rx) consists of four hydrophones (H2a, Aquarian) and two PCM recorders (PCM-M10, Sony). Both hydrophones and PCM recorders were mounted on a remote control boat, as shown in **Fig. 3**.

Table 1 Parameter settings for the experiments.

	Normal OSDM	D-OSDM
Message length	$M$ 189	63
Number of messages / group	$P$ 1	1
Number of groups	$U$ 1	1
Maximum Doppler shift	$Q$ 0	1
Maximum delay spread	$L$ 60	60
Coding (code rate)	Turbo (1/3)	N/A
Modulation	QPSK	QPSK
Carrier frequency (kHz)	35	35
Signal bandwidth (kHz)	1.2	1.2
Data rate (kbps)	0.3	0.3

In such an environment, UWA communication using D-OSDM and normal OSDM were performed. **Table I** shows the parameter settings of D-OSDM and normal OSDM for the experiments. We set the parameters in order to compare the performance of D-OSDM and normal OSDM under the same block length, data rate, and signal bandwidth, to show the advantages of D-OSDM. The Tx firstly transmitted a combination of a channel probe and the D-OSDM signal continuously during the boat operation. Once the boat returned to the pier, the Tx switched to transmit a normal OSDM signal and the boat operation was performed again.

### 3. Experimental Results

**Fig. 3** shows the experimental results. We firstly focus on the relationship between time and ISNR [Fig. 3(a)]. As shown in the figure, ISNR slightly decreases as the distance between Tx and Rx increases, and the ISNRs of D-OSDM and normal OSDM are almost the same. Fig. 3(b) shows the cumulative number of bit errors in D-OSDM and normal OSDM, observed from the experiment. As shown in the figure, the number of bit errors in normal OSDM is larger than that in D-OSDM, although normal OSDM employs powerful channel coding techniques. In detail, the number of bit errors observed in normal OSDM throughout the experiment, is approximately 1.7 times larger than that observed in D-OSDM. This means that D-OSDM is more effective than normal OSDM with channel coding if we compare them under the same environment. We also have compared the relation between ISNRs and BERs, as shown in Fig. 3(c). This figure was obtained by calculating the mean BERs at a specific range of ISNRs (0 to 25 dB, every 1 dB). As shown in the figure, D-OSDM achieves no error when the ISNR is more than 8 dB, while normal OSDM has a BER of  $10^{-2}$  when the ISNR is around 10 dB. This characteristic (bit errors remain even in large ISNR when there exists Doppler spread) agrees with the simulation and test-tank experimental results in Ref. 1. Consequently, we found that D-OSDM is more attractive than normal OSDM with channel coding for UWA communication in doubly spread channels.

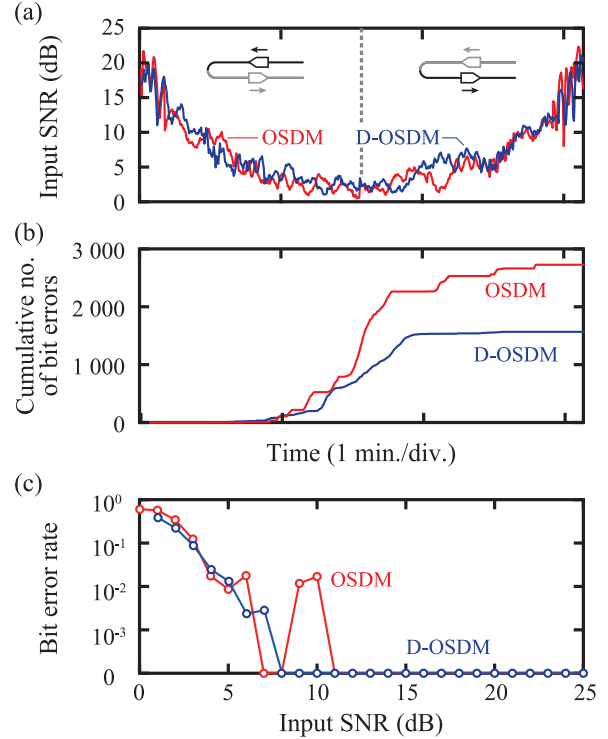

Fig. 3 Experimental results: relationship between time and (a) ISNR, (b) cumulative number of bit errors, and (c) relationship between ISNR and BER.

### 4. Conclusions

In this paper, UWA communication in a harbor was carried out to demonstrate the advantage of our proposed D-OSDM system. By mounting an Rx on a remote control boat, the performance of D-OSDM and normal OSDM was compared under Doppler spread with various ISNRs. The obtained results suggest that D-OSDM achieved a better performance than that of normal OSDM. More detailed comparisons, e.g., between the performances of D-OSDM and D-OFDM will be performed as our future work.

### Acknowledgment

The authors would like to thank Prof. K. Mizutani, N. Wakatsuki, Mr. S. Ogiso, Y. Imai, T. Kawagishi, and M. Mito for their help in conducting the experiment. This work was supported by Grant-in-Aid for Young Scientists (A), Japan Society for Promotion of Science (15H05560).

### References

1. T. Ebihara and G. Leus: *IEEE J. Ocean. Eng.* **41** (2016) 408.
2. T. Ebihara and K. Mizutani: *IEEE J. Ocean. Eng.* **39** (2014) 47.
3. T. Ebihara, H. Ogasawara and K. Mizutani: *J. Mar. Aco. Soc. Jpn.* **41** (2014) 157.
4. Z. Wang, S. Zhou, G.B. Giannakis, C.R. Berger, and J. Huang: *IEEE J. Ocean. Eng.* **37** (2012) 14.