

Low frequency limit characteristics in complex series dynamics and its advantages from engineering point of view

複素級数力学における低周波極限の特性と工学的利点

Michio Ohki (Natl. Def. Acad., Japan)
大木 道生 (防大)

1. Introduction

In the analysis of electromechanical coupling systems, some equivalent-circuit methods based on Newtonian mechanics have been utilized, and they include some lumped-parameter components in order to represent the interaction process between elastic phenomenon and dielectric phenomenon. On the other hand, the distributed-parameter-based treatment of vibration analysis has been developed without using any lumped parameter components, in which the “energy mode” propagates and interferes with each other in a manner of “probabilistic” superposition inside a transducer. The distributed-parameter-based treatment is appropriate for investigating local properties of the transducer. The concept of energy mode is derived from Dirac's “complex (non-real) dynamical variable” in which its magnitude is proportional to the square root of stored energy, and the energy mode also has a property of phase that causes propagation and interference phenomenon.

In this methodology, the calculation of energy mode's infinite geometric series that reflects the boundary condition of the transducer leads to the characteristics of the transducer from the viewpoint of stored energy---This methodology is termed “complex series dynamics”.¹⁻⁵⁾ The phenomenon of electromechanical coupling is treated by considering the interaction between “elastic mode” and “dielectric mode”. The elastic mode and dielectric mode are considered to be coupled in two types of unitary (energy-conservative) processes: One is termed “point interaction” in which a finite quantity of coupling between the two modes occurs on a spatial point with an infinitesimal interaction length, and the other is termed “continuous interaction” in which an infinitesimal quantity of coupling between the two modes occurs in an integral manner in a finite interaction length, as shown in Fig.1 conceptually.

In the analysis of an electromechanical transducer, its low-frequency-limit characteristics are important, since the electromechanical coupling coefficient is defined at the situation of low frequency limit. In this study, by investigating the situation of low frequency limit in the conventional equivalent-circuit methods

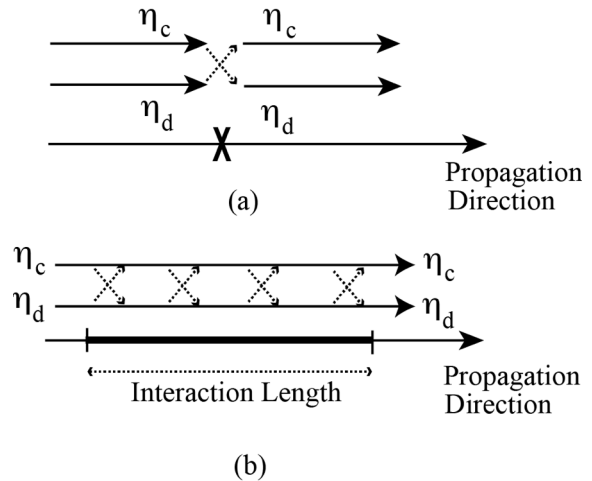

Fig. 1 Two types of unitary (energy-conservative) processes between elastic mode η_c and dielectric mode η_d : (a) point interaction, and (b) continuous interaction.

and the complex series dynamics, some problems included in the conventional methods are discussed, and the advantages of the complex series dynamics are clarified.

2. Treatment of Interaction Phenomenon

The elastic mode η_c has a propagation multiplying factor d_c in the form of

$$d_c = \exp(-jkx - \alpha_c) = \exp(-j\omega x/c - \alpha_c), \quad (1)$$

where j is the imaginary unit, x is a one-dimensional coordinate in the direction of elastic wave propagation, k is a wavenumber vector of the elastic wave, α_c is a loss factor, ω is an angular frequency of the elastic wave, c is the acoustic velocity, respectively. The transducer is divided into multiple layers in the wave propagation direction, and η_c has a reflection factor r_c at the boundary between spatial domains $\#i$ and $\#i+1$, when η_c propagates through from $\#i$ to $\#i+1$, given by

$$r_c = \{Z_c(i) - Z_c(i+1)\} / \{Z_c(i) + Z_c(i+1)\}, \quad (2)$$

where $Z_c(i)$ is a mechanical impedance in $\#i$.

On the other hand, the dielectric mode η_d is always regarded as a static one; that is, low frequency limit of wave propagation is considered essentially, and has a propagation multiplying factor d_d in the form of

$$d_d = \exp(-\alpha_d), \quad (3)$$

where α_d is a loss factor. η_d is expected to have a similar reflection multiplying factor to r_c , given by

$$r_d = \{Z_d(i) - Z_d(i+1)\} / \{Z_d(i) + Z_d(i+1)\}, \quad (4)$$

where $Z_d(i)$ is a quantity corresponding to ‘‘impedance’’ for dielectric mode in $\#i$.

In ref. 2, a system composed of homogeneous N spatial domains was treated, where

$$\begin{aligned} Z_c(1) &= Z_c(2) = \dots = Z_c(N), \\ Z_d(1) &= Z_d(2) = \dots = Z_d(N), \end{aligned} \quad (5)$$

(impedance matching system), with all N domains piezoelectrically driven. The configuration of electrodes is shown in Fig. 2(a) in the case of longitudinal (L-) effect, and in Fig. 2(b) in the case of transverse (T-) effect. Figure 2(c) shows the division of the system in the case of $N = 4$.

The point interaction shown in Fig. 1 was empirically found out to occur only at the ‘‘edges’’ of the system with length $\delta \rightarrow 0$ shown in Fig. 2(c), that is, in the form of Dirac’s spatial delta function. This treatment leads to physically appropriate results when the electromechanical coupling occurs; that is, the acoustic velocity of the system is changed, and the resonance frequencies are shifted. The resonance curve is symmetrical about the resonance frequency, whether the electromechanical coupling occurs or not. This behavior is different from that in the classical admittance near the resonance with asymmetrical characteristics due to the ‘‘dip’’ in admittance at antiresonance.

The location of positions on which the point interaction occurs is highly-related with the result of probabilistic superposition of dielectric mode. In the spatial N -domain system with the boundary condition mentioned above, if the dielectric mode behaves independently of the elastic mode, that is, without any interaction with elastic mode, the probabilistic superposition of dielectric mode leads to

$$(\eta_{d\{1\}}, \eta_{d\{2\}}, \dots, \eta_{d\{N-1\}}, \eta_{d\{N\}}) \sim (1, 0, \dots, 0, 1) \quad (6)$$

in the frequency domain (not in the time domain), where $\eta_{d\{i\}}$ (normalized appropriately) is the resultant

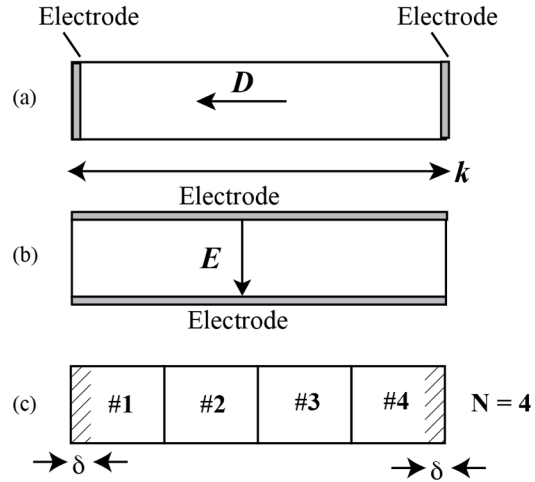

Fig. 2 Electromechanical coupling system for (a) longitudinal (L-) effect and (b) transverse (T-) effect. (c) Division of the whole domain into N domains.

dielectric mode after superposition observed on the spatial domain $\#i$. As the number N is increased, the dielectric mode is ‘‘localized’’ at the ‘‘edges’’ of the system, which equals to the positions where the point interaction is assumed to occur. In the framework of the complex series dynamics, such consideration of localization leads to physically appropriate results when the electromechanical coupling occurs.

On the other hand, in the conventional methods, the consideration of low frequency limit leads to the ‘‘non-localized’’ or spatially homogeneous situation. For example, the ‘‘dip’’ in admittance at antiresonance is caused by the dielectric capacitance that is regarded as spatially homogeneous in the frequency domain, and the ‘‘dip’’ leads to an undesirable result in the time domain when the inverse Fourier transform is considered, as pointed out in ref. 1.

1. M. Ohki: "Impulse response for electromechanical coupling system on a distributed-parameter basis", Jpn. J. Appl. Phys., **53**, 07KB03 (2014)
2. M. Ohki: "Application of Complex Series Dynamics to Electromechanical Coupling System", Jpn. J. Appl. Phys., **50**, 07HB05 (2011).
3. M. Ohki: "Impulse Response of Piezoelectric Transducer by Multiresolution Analysis of Energy Modes", Jpn. J. Appl. Phys., **46** (2007) 4474.
4. M. Ohki: "Probabilistic Superposition of Energy Modes for Treating 2N-Layered Mechanical Impedance Mismatch System", Jpn. J. Appl. Phys., **45** (2006) 4462.
5. M. Ohki: "Distributed-Parameter Based Treatment of Interaction Process between Elastic and Dielectric Energy in Piezoelectric Transducer", Jpn. J. Appl. Phys., **44** (2005) 8536.