

## Multifunctional Pulse Generator for High-Intensity Focused Ultrasound System

超音波治療システム用多機能パルス発生回路

Satoshi Tamano<sup>1,2†</sup>, Shin Yoshizawa<sup>1</sup>, and Shin-Ichiro Umemura<sup>3</sup>

(<sup>1</sup> Graduate School of Engineering, Tohoku Univ., <sup>2</sup> Hitachi, Ltd.,

<sup>3</sup> Graduate School of Biomedical Engineering, Tohoku Univ.)

玉野 聡<sup>1,2†</sup>, 吉澤 晋<sup>1</sup>, 梅村 晋一郎<sup>3</sup>

(<sup>1</sup> 東北大学大学院 工学研究科, <sup>2</sup> 日立製作所, <sup>3</sup> 東北大学大学院 医工学研究科)

### 1. Introduction

An either pulse or continuous wave (CW) drive circuit which drives an ultrasonic transducer at a high voltage is an important component in any ultrasound system. Especially, in a high-intensity focused ultrasound (HIFU) system with multi-channel focusing, to realize a compact and highly reliable ultrasonic transmission circuit is a major challenge. We have already proposed a four-stage high-voltage staircase HIFU transmission circuit<sup>1)</sup>, which has a pair of P-channel and N-channel MOSFETs for each power supply stage, and reported its effectiveness. The proposed method could reduce the excessive spike noise caused by the switching operation of the MOSFET, without depending on the load characteristics. By applying the proposed circuit to a number of power supply stages, generating a pseudo sinusoidal waveform becomes possible. At "triggered HIFU" mode<sup>2,3)</sup>, requiring short and extremely high voltage (> 300 Vpp) pulse transmission, followed by middle-range voltage (< 100 Vpp) long burst ultrasound transmission. Our proposed circuit is effective for suppressing the flyback voltage during the MOSFETs switchings. Therefore, it is possible to suppress the excessive device heating and prevent from the device breakdown. We already reported that, using cavitation bubble induced by second-harmonic superimposing wave could accelerate the lithotripsy erosion rate<sup>4)</sup>. In particular, using of the peak-negative-enhanced waveform, the maximum erosion rate was  $232 \pm 32$  mg / min. In order to realize the above mentioned ultrasonic insonification efficiently, we further developed a prototype transducer using a heavy matching layer<sup>5)</sup>, which can transmit second-harmonic superimposed waves. The measurement results with a prototype transducer show that our transducer is suitable for the superimposed transmission at 1 and 2 MHz. The objective of the present paper is to develop an ultrasonic transmission system, not only for high-intensity focused ultrasound treatment, but also for cavitation accelerated lithotripsy.

### 2. Material and Methods

#### 2.1. System description

Figure 1 shows a block diagram of the proposed pulse generator system. In order to develop a pulse generator system of more than 128 channels, the control board and the transmission boards are separated.

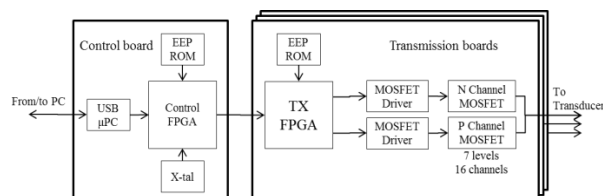

Fig. 1. Block diagram of multifunctional pulse generator.

The control board have a USB microcontroller. The transmission commands, transmission waveform data, and transmission delay data are interfaced from an external PC to the USB microcontroller. The control FPGA is a circuit for arbitrating a bus between each transmission boards and the USB microcontroller. The TX FPGA controls the actual ultrasonic transmission. When the transmission commands are delivered from the external PC to the TX FPGA, it acts as on the basis of the transmission waveform data and the transmission delay information, then it sends a drive signal to the MOSFET-drivers. The MOSFET-driver drives the gate terminals of the high-speed N-channel and P-channel MOSFETs. Transmitting ultrasonic waves at predetermined voltages is possible thereby. In order to generate a pseudo sinusoidal waves, we use three-stages of positive and negative power supply, respectively. In addition, for preventing unnecessary transmission during the non-transmission period, ground level dumping could be selected. Figure 2 shows the specific diagram of our proposed HIFU transmission circuit with seven-stages in total.

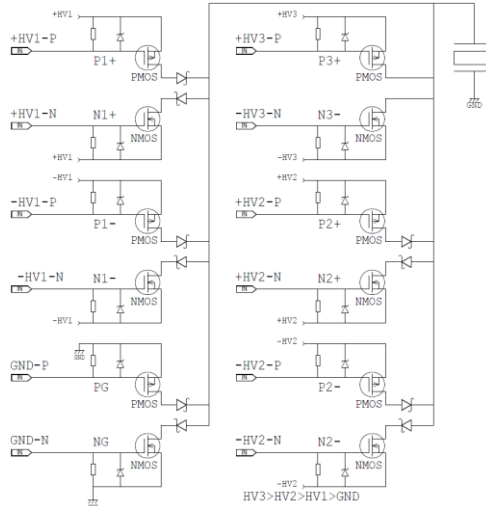

Fig. 2. Proposed HIFU transmission circuit.

## 2.2. Dual transmission frequency transducer

Figure 3(a) shows the external view of the prototype dual transmission frequency transducer (Japan Probe, JAR810), and Fig. 3(b) shows its frequency characteristics. Along with the low impedance at 1 MHz and 2 MHz, the phase is closer to zero at these frequencies. Therefore, efficient transmission at both frequencies is expected for this prototype transducer.

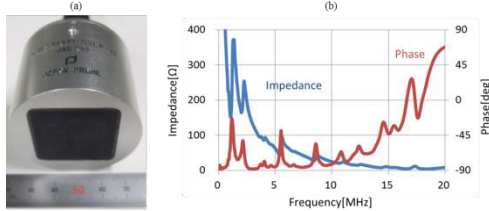

Fig. 3. Dual transmission frequency transducer: (a) external view, (b) frequency characteristics.

## 3. Results and discussion

First, we examined the performance of the proposed circuit to suppress the harmonic components generated by the prototype transducer. Figure 4 shows the CW transmission waveform at 1 MHz with the transmission amplitude set to 40 Vpp along with its power spectrum. Since our transmission circuit uses staircase configuration with seven stages, the 3-rd and 5-th harmonic components were reduced to -44.3, -81.5 dB respectively. It can be seen that the harmonic components were sufficiently suppressed.

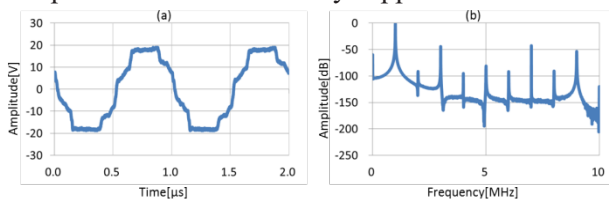

Fig. 4. 1.0 MHz CW transmission: (a) waveform and (b) power spectrum.

Then we checked the effect to suppress spike noise in the triggered-HIFU mode. The pulse transmission voltage for generating the cavitation bubbles was set to 350 Vpp, and the burst transmission voltage to achieve the *in vivo* temperature rise was set to 80 Vpp. The transmission waveform in the triggered HIFU mode at 1 MHz is shown in Fig. 5. As a result, no significant excessive spike noise is seen in the waveform.

Finally, we observed the second harmonic superimposed waveform generated by the proposed circuit. The peak-negative-enhanced waveform is shown in Fig 6. In this experiment, the ratio of fundamental and the second harmonic was set to 1:1. It was confirmed that the transmission waveform was close to what was intended. The phase shifts at both frequencies between the electric and ultrasonic signals must be considered to obtain peak-negative-enhanced pressure at the focus.

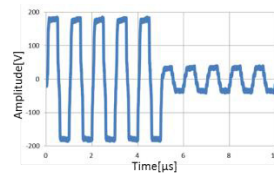

Fig. 5. Triggered HIFU waveform, 1.0MHz transmission.

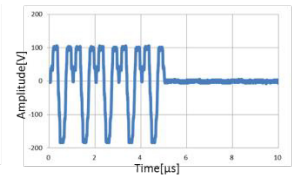

Fig. 6. Peak-negative-enhanced waveform.

## 4. Conclusions

We proposed a HIFU transmission suitable for not only the triggered-HIFU mode exposure but also the peak-negative-enhanced exposure suitable for cavitation accelerated lithotripsy. The proposed circuit is effective for reducing high-order harmonics, and will enhance the efficiency and safety of HIFU transmission circuit especially in the triggered-HIFU mode. Since the proposed circuit can also generate a dual frequency waveform, it should be also useful for cavitation accelerated lithotripsy if combined with a dual frequency HIFU transducer.

## Acknowledgment

This work was partially supported by Japan Agency for Medical Research and Development, AMED.

## References

1. S. Tamano, S. Yoshizawa, and S. Umemura, Jpn. J. Appl. Phys. **55**, 07KF17 (2016).
2. R. Iwasaki, S. Yoshizawa, and S. Umemura, Jpn. J. Appl. Phys. **54**, 07HF11 (2015).
3. K. Goto, S. Yoshizawa, and S. Umemura, Jpn. J. Appl. Phys. **54**, 07HF12 (2015).
4. M. Osuga, S. Yoshizawa, and S. Umemura, Jpn. J. Appl. Phys. **55**, 07KF18 (2016).
5. Z. Zaini, S. Yoshizawa, and S. Umemura, Jpn. J. Appl. Phys. **55**, 07KF15 (2016).